

SPECIFICATIONS

NI DCM-2301

Embedded Direct Injector Control and Measurement (DCM) Device
with Real-Time Processor and Reconfigurable FPGA

Preliminary

*The contents of this document are preliminary and are subject to change without notice.
This document may contain errors, omissions, or information that no longer applies.*

This document lists the specifications for the National Instruments DCM-2301. The following specifications are typical for the 0 °C to 55 °C operating temperature range unless otherwise noted.



Caution Do not operate the NI DCM-2301 in a manner not specified in this document. Product misuse can result in a hazard. You can compromise the safety protection built into the product if the product is damaged in any way. If the product is damaged, return it to NI for repair.

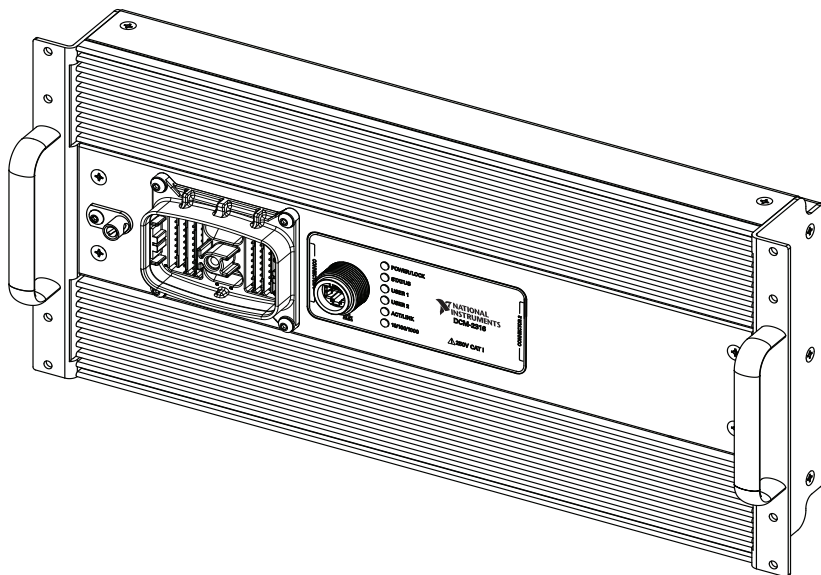

Processor

Type	Xilinx Zynq-7000, XC7Z020 All Programmable SoC
Architecture	ARM Cortex - A9
Speed	667 MHz
Cores	2
Operating system	NI Linux Real-Time (32-bit)
Nonvolatile memory	512 MB, SLC NAND Flash
Volatile memory (DRAM)	512 MB, DDR3
Real-time clock accuracy	5 ppm
Flash reboot endurance	100,000 cycles

For information about the life span of the nonvolatile memory and about best practices for using nonvolatile memory visit ni.com/info and enter Info Code `SSDBP`

Reconfigurable FPGA

Type	Xilinx Zynq-7000, XC7Z020 All Programmable SoC
Number of logic cells	85,000
Number of flip-flops	106,400
Number of 6-input LUTs	53,200
Number of DSP slices (18 x 25 multipliers)	220
Available block RAM	560 KB
Number of DMA channels	16
Number of logical interrupts	32



Note The DCM-2301 internally utilizes the NI sbRIO-9651 System on Module as the digital processing core.

Network/Ethernet Port

Number of ports	1
Network interface	10Base-T, 100Base-T, and 1000Base-T Ethernet
Compatibility	IEEE 802.3
Communication rates	10 Mbps, 100 Mbps, 1000 Mbps, auto-negotiated
Maximum cabling distance	100 m/segment

Connector 1

Connector 1 Mating Plug Manufacturer Specifications

Number of Pins	86
Mating Connector Plug	<ul style="list-style-type: none">• Deutsch P/N: DRCP28-86SA
Mating Connector Contacts For Pins 1-80 (large wires)	
Manufacturer Specifications	<ul style="list-style-type: none">• Deutsch P/N: 0462-005-20141• Contact Size #: 20• Wire Size: 18 AWG - 16 AWG• Continuous Current Rating: 7.5 A• Color Marking: Purple band• Material: Nickel• Wire strip length: 0.17 in (4.32 mm)
Mating Connector Contacts For Pins 1-80 (small wires)	
Manufacturer Specifications	<ul style="list-style-type: none">• Deutsch P/N: 0462-201-20141• Contact Size #: 20• Wire Size: 20 AWG• Continuous Current Rating: 7.5 A• Color Marking: None• Material: Nickel• Wire strip length: 0.17 in (4.32 mm)

Connector 1 Mating Plug Manufacturer Specifications

Mating Connector Contact For
Pins 81-86

- | | |
|-----------------------------|---|
| Manufacturer Specifications | <ul style="list-style-type: none">• Deutsch Part Number: 0462-203-12141• Contact Size #: 12• Wire Size: 14 AWG - 12 AWG• Continuous Current Rating: 25 A• Color Marking: None• Material: Nickel• Wire strip length: 0.25 in (6.35 mm) |
|-----------------------------|---|

Connector 1 securement tool	4 mm hex key
-----------------------------	--------------

Connector 1 securement torque	44 in/lb to 62 in/lb (5 Nm to 7 Nm)
-------------------------------	-------------------------------------

- | | |
|--|---|
| Connector 1 hand-crimper tool for solid contacts | <ul style="list-style-type: none">• Deutsch Part Number: HDT-48-00• Supported Contact Size #: 20, 16, 12 |
|--|---|



Note Connector 1 mating plug, assortment of contacts, and hex key tool are included in DCM accessory part number 785113-01



Note Connector 1 hand-crimper for solid contacts is included in NI DCM accessory part number 785202-01

Figure 1. DCM Connector 1 Face

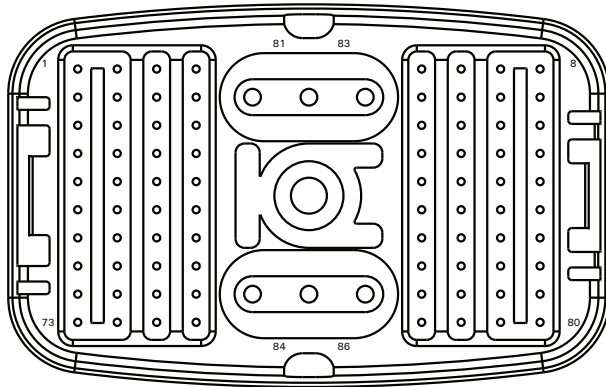

Figure 2. DCM Connector 1 Pinout

HH1	1	DI_S_A1	2	DI_P_A1	3	DI_L_A1	4					DIO1a	5	DIO2a	6	DIO3a	7	BATT	8
HH2	9	DI_S_A2	10	DI_P_A2	11	DI_L_A2	12					DIO1b	13	DIO2b	14	DIO3b	15	MPRD	16
HH3	17	DI_S_A3	18	NC	19	NC	20					DIO4a	21	DIO5a	22	DIO6a	23	KEY	24
HH4	25	NC	26	NC	27	NC	28					DIO4b	29	DIO5b	30	DIO6b	31	IO_LOCK+	32
NC	33	NC	34	HV_A	35	DI_L_AP	36					DIO7a	37	DIO8a	38	DGND	39	IO_LOCK-	40
NC	41	NC	42	NC	43	NC	44					DIO7b	45	DIO8b	46	AGND	47	CAN_H	48
NC	49	NC	50	NC	51	NC	52					Ai4	53	Ai18	54	Ai12	55	CAN_L	56
NC	57	NC	58	NC	59	NC	60					Ai3	61	Ai17	62	Ai11	63	IGND	64
NC	65	NC	66	NC	67	NC	68					Ai2	69	Ai6	70	Ai10	71	RS232_TX	72
NC	73	NC	74	NC	75	NC	76					Ai1	77	Ai5	78	Ai9	79	RS232_RX	80

Figure 3. DCM Connector 1 Recommended Contact and Wire Size

Contact Size #/ Wire Size (awg)

20/16	1	20/16	2	20/16	3	20/16	4					20/20	5	20/20	6	20/20	7	20/20	8
20/16	9	20/16	10	20/16	11	20/16	12					20/20	13	20/20	14	20/20	15	20/20	16
20/16	17	20/16	18	NC	19	NC	20					20/20	21	20/20	22	20/20	23	20/20	24
20/16	25	NC	26	NC	27	NC	28					20/20	29	20/20	30	20/20	31	20/20	32
NC	33	NC	34	20/16	35	20/16	36					20/20	37	20/20	38	20/20	39	20/20	40
NC	41	NC	42	NC	43	20/16	44					20/20	45	20/20	46	20/20	47	20/20	48
NC	49	NC	50	NC	51	NC	52					20/20	53	20/20	54	20/20	55	20/20	56
NC	57	NC	58	NC	59	NC	60					20/20	61	20/20	62	20/20	63	20/20	64
NC	65	NC	66	NC	67	NC	68					20/20	69	20/20	70	20/20	71	20/20	72
NC	73	NC	74	NC	75	NC	76					20/20	77	20/20	78	20/20	79	20/20	80

Powers Requirements and Power Control

Related Connector 1 Pins:	BATT DRVP (3x) PGND (3x) MPRD AGND DGND IGND Chassis Ground
---------------------------	--

BATT to PGND

Absolute min/max input voltage range	6 V to 48 V
--------------------------------------	-------------

Recommended input voltage range	9V to 48 V
---------------------------------	------------

Note: A combination of circuitry and low-level software is implemented to prevent large inrush current to the DRVP circuit capacitance.

When voltage is applied to the BATT pin, the following occurs:

- The sbRIO-9651 controller boots
- Digital and analog circuits are powered
- The battery input circuit begins trickle-charging the DRVP circuit capacitance
- MPRD is disabled until DRVP voltage is greater than 9 V and within 2 V of BATT

After MPRD is switched ON, BATT voltage is continuously monitored for a low-voltage fault, triggered by dropping below 7 V.

Refer to **Figure 4** for a diagram of the BATT, DRVP and MPRD circuits.

Reverse polarity protection	-48 V
-----------------------------	-------

Maximum inrush current	3 A
------------------------	-----

Continuous current (BATT =12 V)	750 mA to 2000 mA typical
---------------------------------	---------------------------

Powers Requirements and Power Control

Recommended fuse in-line with BATT	7.5 A, Fast-Acting
Recommended BATT wire size	16 AWG
Input capacitance	100 μ F
DRVP to PGND	
Absolute min/max input voltage range	6V to 48 V
Recommended input voltage range	9 V to 48 V
Reverse polarity protection	-48 V
Maximum continuous current (each pin)	25 A
Recommended fuse in-line with DRVP (3x)	25 A, Fast-Acting
Recommended DRVP wire size	12 AWG
Input capacitance	3300 μ F
MPRD low-side switch to PGND	
Configuration	<ul style="list-style-type: none"> • Low-side MOSFET switch to PGND • Short-circuit and over-load protection • Thermal shutdown protection • Suitable for resistive and inductive loads
Maximum withstand voltage	60 V
Maximum continuous current	2 A
Short-circuit / over-load shutdown current	6 A

Powers Requirements and Power Control

Internal flyback diode	No
	Note: The MPRD low-side MOSFET switch is internally protected against back-EMF of inductive load switching. However, it is recommended to use an external flyback diode in parallel with the inductive load. The PDU-2300 utilizes relays which contain internal flyback diodes.
Recommended external main power relay	12 V or 24 V coil, 75 A switch (see note below)
PGND maximum continuous current (each pin)	25 A
Recommended PGND wire size	12 AWG
DGND maximum continuous current	2 A
AGND maximum continuous current	2 A
IGND isolation voltage (IGND to all other system grounds)	250 VDC
IGND maximum continuous current	500 mA
PGND, DGND & AGND configuration	<p>Note: Pins PGND, DGND and AGND are internally connected. However, they must only be used for their explicit purpose, as follows:</p> <p>PGND pins (3x) may be used as a power ground return path for BATT and DRVP pins.</p> <p>A 12 AWG wire should be connected between battery ground and earth ground as shown in Figure 4.</p> <p>DGND pin may be used as a ground reference only for digital IO signals DIOxa and DIOxb. Do not use DGND as a power ground return path for BATT or DRVP. Otherwise, the DCM may be damaged.</p> <p>AGND pin may be used as a ground reference only for external analog input pins AIx and KEY. Do not use AGND as a power ground return path for BATT or DRVP. Otherwise, the DCM may be damaged.</p>

Powers Requirements and Power Control

IGND

Note: IGND is provided as a ground reference for isolated circuits CAN, RS-232 and IO_LOCK. IGND is isolated from all other DCM grounds. IGND may only be used as a reference for CAN, RS-232 and IO_LOCK pins.

Note: While IO_LOCK pins belong to the isolated circuitry, it is not necessary to utilize IGND with IO_LOCK+ and IO_LOCK- because they operate with an external passive ESTOP switch.

Chassis Ground

Note: A chassis ground lug is provided on the DCM enclosure next to Connector 1 (see **Figure 5**). A 12 AWG wire should be connected between the chassis ground lug and earth ground.

Maximum power input

1000 W

Maximum power consumption

200 W



Note The NI PDU-2300 and DCM 23XX Starter harness accessories are designed specifically for the DCM-23XX. These accessories utilize the recommended relays, fuses and wire sizes specified in this document.



Note The maximum power consumption specification is based on a system running a high-stress application. Measurement Category I is for measurements performed on circuits not directly connected to the electrical distribution system referred to as MAINS voltage. MAINS is a hazardous live electrical supply system that powers equipment. This category is for measurements of voltages from specially protected secondary circuits. Such voltage measurements include signal levels, special equipment, limited-energy parts of equipment, circuits powered by regulated low-voltage sources, and electronics.



Caution Do not connect the DCM-2301 to signals or use for measurements within Measurement Categories II, III, or IV.



Note Measurement Categories CAT I and CAT O are equivalent. These test and measurement circuits are not intended for direct connection to the MAINS building installations of Measurement Categories CAT II, CAT III, or CAT IV.

Figure 4. Battery Input, DRVP Input and MPRD Control Diagram

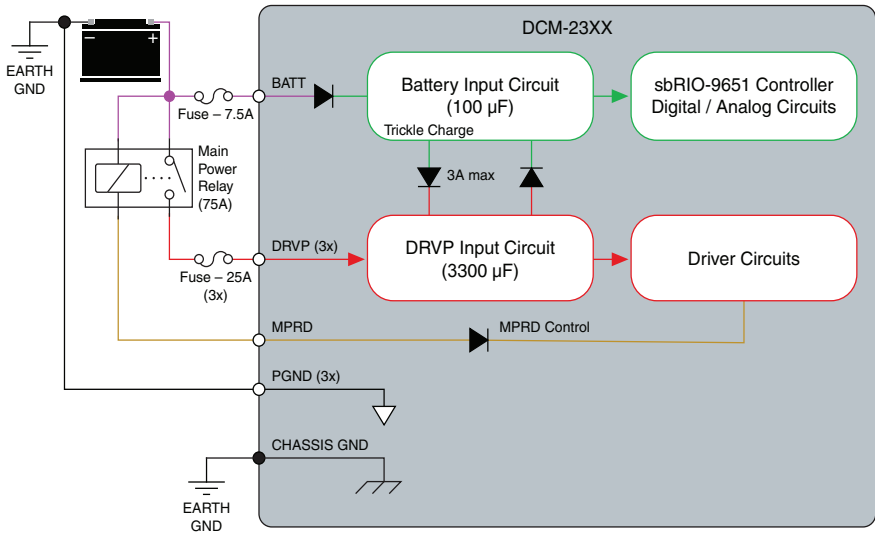
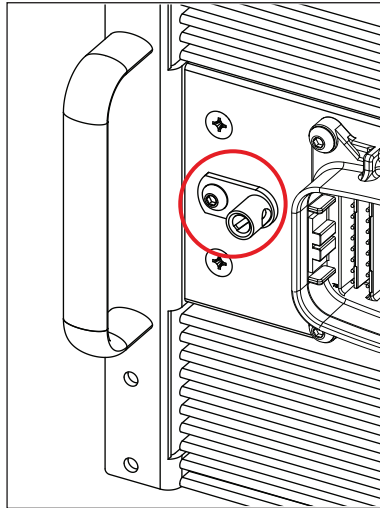

Table 1. Recommended Fuse Part Numbers (Referenced in Figure 4)

Manufacturer	Amps	Part Number
Littelfuse	7.5 A	099707.5.WXN
Littelfuse	25 A	0997025.WXN

Figure 5. Chassis Ground Lug



Direct Injector (DI) Half-H Driver Channels

Related Connector 1 Pins	DI_S_xy DI_P_xy DI_L_xy DI_L_xP (x = bank A, y = 1- 3)
Topology	<ul style="list-style-type: none"> • Single Bank A • Two independent DI Half-H driver circuits • Secondary stage boost or DRVP drive source for each DI Half-H high-side pin • Dedicated high-side pins for solenoid and piezo injector loads, with internal series inductance on piezo pins • Dedicated fuel pump low-side driver per bank • Programmable DI-Zener clamp for each DI Half-H low-side pin • Additional programmable pump-Zener clamp with independent set-point • Low-side current sense for each DI Half-H and pump pin • Differential voltage measurements for each DI Half-H and pump pins • Multiple modes of operation, supporting solenoid and piezo injectors, unipolar and bipolar drive, multiplexed channels, and engine-synchronous fuel pump <p>Note: Refer to Figure 6 for a circuit topology showing two DI Half-H driver circuits</p>
Maximum drive voltage from secondary boost power supply	220 V
Maximum drive voltage from DRVP	48 V
Maximum drive current (solenoid operation)	+/- 40 A
Maximum drive current (piezo operation)	+/- 10 A

Direct Injector (DI) Half-H Driver Channels

Current control methods (solenoid and piezo injector modes)	<ul style="list-style-type: none"> • Closed loop: Uses hardware DAC set-point to comparator with current sense feedback • Two DACs and two comparators per channel for upper and lower current dither set-points
Current sense range	-12 A to +50 A
Current control resolution	60 mA
Voltage control methods (piezo injector modes)	<ul style="list-style-type: none"> • Closed loop: Uses hardware DAC set-point to comparator with voltage sense feedback • Two DACs and two comparators per channel for upper and lower voltage range set-points
Voltage sense range	-250 V to +250 V
Piezo voltage control resolution	500 mV
Internal series inductor between high-side voltage drive and DI_P_xy	47 μ H @ 100 kHz (1 V) ISat = 9.5 A DCR = 90 m Ω
Modes of operation (each bank)	<ul style="list-style-type: none"> • 2 unipolar solenoid injectors, 1 pump • 1 unipolar piezo injectors, 1 pump • 1 bipolar solenoid injectors, 1 pump • 1 bipolar piezo injectors, 1 pump • 4 unipolar solenoid multiplexed injectors, 1 pump • 5 unipolar solenoid multiplexed injectors, no pump • 2 unipolar piezo multiplexed injectors, no pump <p>Note: Refer to Figure 7 for wiring connections for each mode of operation</p>
High-side high-voltage-drive short circuit protection (short between DI_S_xy and PGND)	90 A - 260 A, depending on secondary boost supply voltage, component tolerances and temperature
High-side low-voltage-drive short circuit protection (short between DI_S_xy and PGND)	70 A - 100 A, depending on DRVP, component tolerances and temperature

Direct Injector (DI) Half-H Driver Channels

Low-side over-current protection threshold
(short between DI_S_xy and DI_L_xy,
or short between DRVP and DI_L_xy)

Programmable DI-Zener clamp

Topology	<ul style="list-style-type: none">• One dedicated programmable DI-Zener set-point per bank• Four DI-Zener clamp circuits per bank
----------	--

Voltage range	DRVP to 150 V
---------------	---------------

Voltage set-point resolution	270 mV
------------------------------	--------

Circuit maximum power dissipation	6 W RMS
-----------------------------------	---------

Programmable pump-Zener clamp

Topology	<ul style="list-style-type: none">• One dedicated programmable pump-Zener set-point per bank• One pump-Zener clamp circuit per bank
----------	--

Voltage range	DRVP to 150 V
---------------	---------------

Voltage set-point resolution	270 mV
------------------------------	--------

Circuit maximum power dissipation	6 W
-----------------------------------	-----

Direct Injector (DI) Half-H Driver Channels

Programmable secondary boost clamp

Topology

- One programmable secondary boost clamp bleed circuits per bank, single set-point for both circuits
- Secondary boost supply is clamped to voltage set-point via a bleed resistor to PGND

Note: Boost clamp is used when the inductive back-EMF power into the boost power supply exceeds the boost power consumed during injections. This prevents the secondary boost supply from being over-charged.

Voltage range

$Max[(DRV P + 5V), (secondary\ set\ point + 5V), 24V]$ to 220 V

Voltage set-point resolution

250 mV

Circuit maximum power dissipation

5 W

Figure 6. DI Half-H Driver Circuit Topology

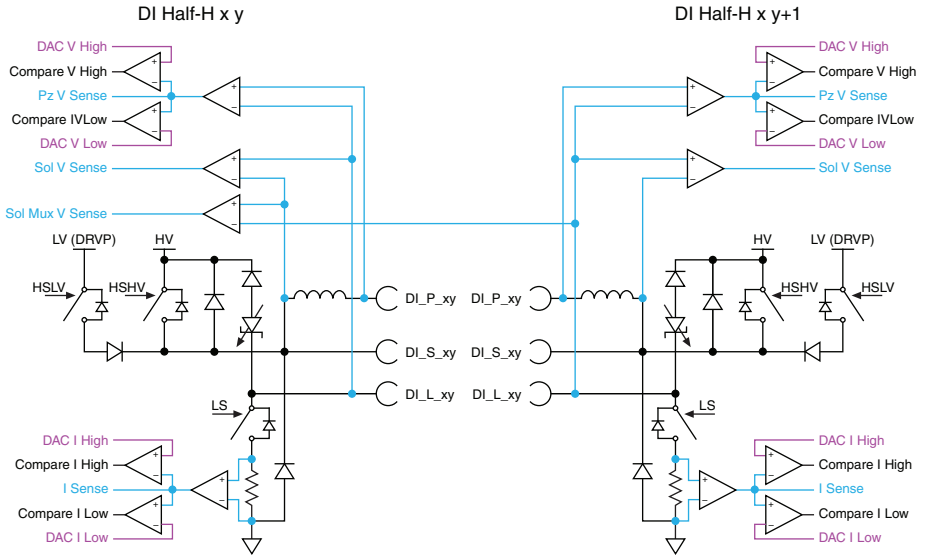
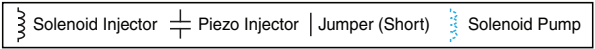
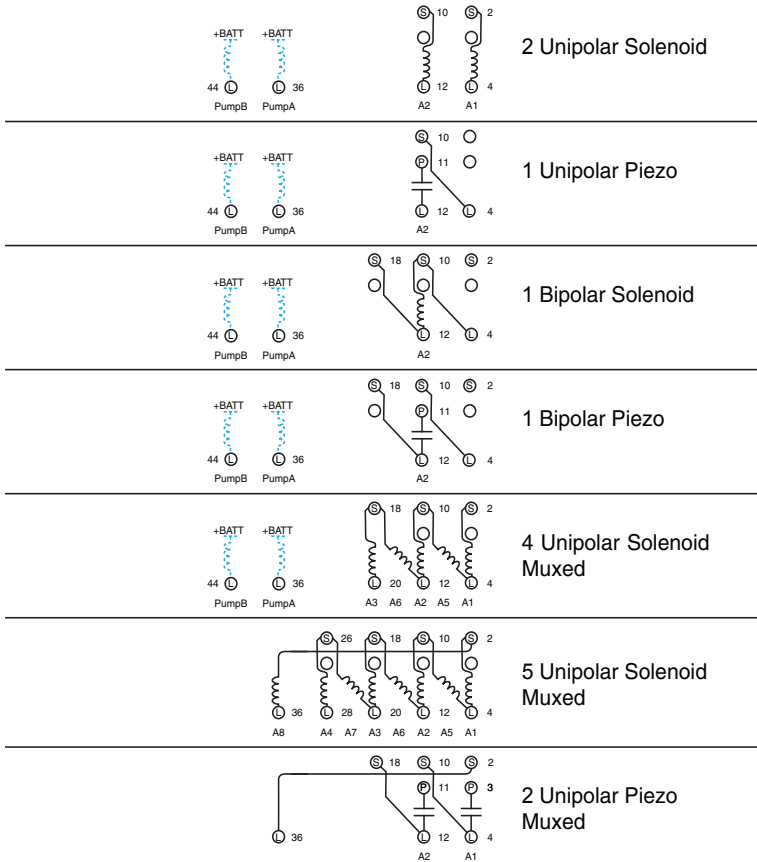

Figure 7. DI Half-H Driver Wiring Connections



Internal Boost Power Supply

Topology	<ul style="list-style-type: none">• Two-stages, Two banks• Dual primary stage and dual secondary stage for Bank A• Dual primary stage and dual secondary stage for Bank B <p>Note: Effectively, the dual primary stage for each bank acts as a unified primary stage, controlled by a single set-point, with connected outputs.</p> <p>Note: The dual secondary stage for each bank is controlled by a single set-point, but has independent outputs.</p> <p>Note: Refer to Figure 8 for the internal boost power supply topology diagram.</p>
Primary stage voltage set-point range	DRVP – 60 V, automatically controlled based on desired secondary voltage Note: The primary stage voltage is automatically set to approximately 10 V less than the user set-point of the secondary stage, until the secondary voltage set-point exceeds 70 V. After this, the primary stage set-point remains at 60 V.
Secondary stage voltage set-point range	DRVP – 220 V Note: If the secondary stage is disabled, its voltage will adapt to the voltage of the primary stage.
Secondary stage voltage set-point resolution	220 mV
Primary stage capacitance (each bank)	2000 μ F, V, Aluminum Electrolytic
Secondary stage capacitance (each supply)	260 μ F, 250 V, Aluminum Electrolytic

Internal Boost Power Supply

Supply recharge time

55 V to 60 V (secondary disabled)	120 μ s
70 V to 75 V	130 μ s
115 V to 120 V	335 μ s
155 V to 160 V	650 μ s
215 V to 220 V	2.32 ms
Time for secondary stage voltage to bleed from 220 V to 60 V after disabled, or after DCM is powered down	130 s

Figure 8. Internal Boost Power Supply Topology

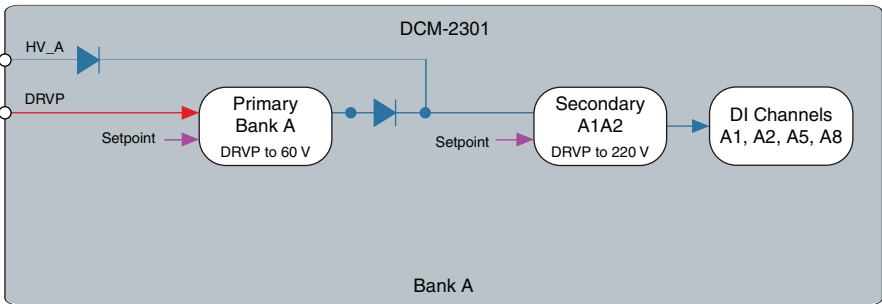

External Boost Supply Inputs

Related Connector 1 Pins	HV_A
Topology	<ul style="list-style-type: none">• HV_A is an external boost supply input to the secondary stage capacitance of Bank A• Each HV_A input connects to the secondary stage capacitance via a series diode, preventing reverse current <p>Note: Refer to Figure 8 for the internal boost power supply topology diagram, which shows how the external boost supply inputs connect to the secondaries</p>
Voltage range	DRVP - 220 V
Maximum current	2.5 A RMS

General Purpose Half H-Bridge Driver Channels

Related Connector 1 Pins	HH1-HH4
Topology	<ul style="list-style-type: none">• Four independent half H-bridge driver circuits• Hardware-controlled “flyback diode” FET, based on operating mode• PFI-Zener clamp circuit for PFI operating mode• Independent current sense, open-circuit, and short-circuit detection for each channel <p>Note: Refer to Figure 9 for the general purpose half H-bridge driver topology</p>

General Purpose Half H-Bridge Driver Channels

Modes of Operation

- Low-side: Half-H channel operates as low-side switch to power ground (PGND), with continuous internal flyback-diode enabled
- High-side: Half-H channel operates as high-side switch to driver-power (DRVVP), with continuous internal flyback-diode enabled
- Port Fuel Injector (PFI): Half-H channel operates as low-side switch to power ground (PGND), with flyback-diode enabled during command, and higher back-EMF clamp at end of command
- Full-H Pair: Adjacent Half-H channels operate as a Full-H sinking/sourcing driver, with continuous flyback-diode enabled
- Independent current measurement ADC for each Half-H channel

Note: Half-H channels only use DRVVP when sourcing, and use PGND when sinking. Half-H channels do not have access to the internal boost power supplies.

Note: Refer to **Figure 10** for the general purpose half H-bridge driver wiring connections for each mode of operation

External voltage range to high-side of load (Low-side and PFI modes) 0 V to DRVVP

Note: Half-H channels are not reverse-battery protected. It is recommended to use the PDU-2300 for power distribution, providing reverse-battery protection and fusing for high-side power to external loads.

External voltage to low-side of load (High-side mode) PGND

PFI-Zener clamp voltage at end of command -26 V, measured differentially across load, DRVVP to HHx

Note: PFI-Zener clamp circuit clamps with respect to DRVVP, not PGND

General Purpose Half H-Bridge Driver Channels

Maximum command frequency (Low-side, High-side and Full-H modes)	5 kHz
Maximum command frequency (PFI mode)	400 Hz Note: This maximum frequency is lower than other modes in order to protect the PFI-Zener clamp circuit
Maximum continuous current	+/- 4 A
Maximum peak current	+/- 8 A
Maximum peak current time	2 ms, not to exceed 10% duty cycle
Current measurement range	+/- 9.17 A
Current measurement resolution	12-bit, 4.5 mA per count
Current measurement rate	500 kS/s
Current control method (Low-side, High-side and PFI modes)	Closed-loop: Channel-independent upper and lower dither set points
Current control method (Full-H mode)	Open loop: min/max current level depends on command frequency and duty cycle for given load resistance and inductance

Figure 9. General Purpose Half H-Bridge Driver Circuit Topology

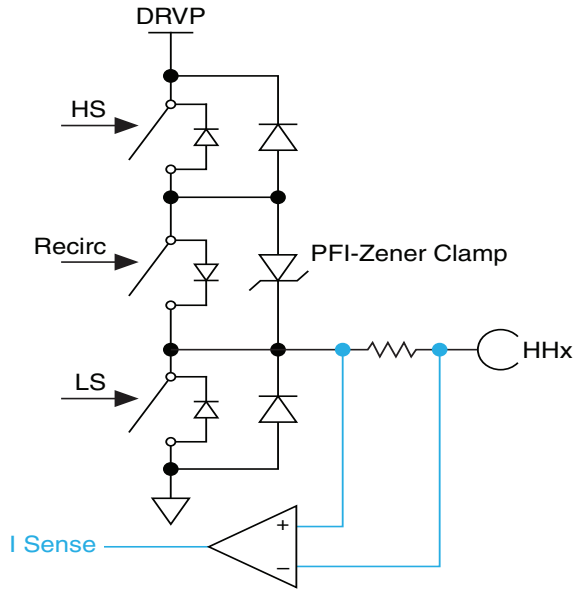
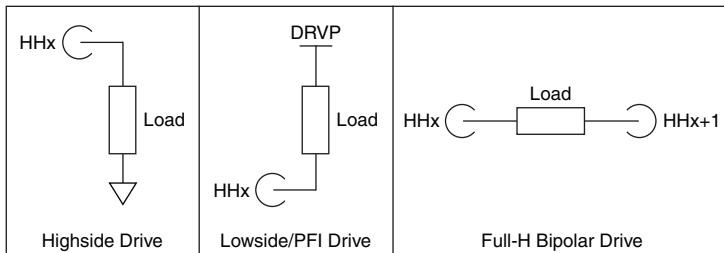

Figure 10. General Purpose Half H-Bridge Driver Wiring Connections



IO Lock

Related Connector 1 Pins

IO_Lock+
IO_Lock-

Configuration

- Locks and unlocks the DI Half-H and general purpose Half-H driver circuit operation at hardware level
- General purpose Half-H driver lockout may be overridden via software on a per-channel basis
- To be implemented with external contact closure, such as an emergency stop switch
- IO Locked (driver circuits disabled): Contact open between IO_LOCK+ and IO_LOCK-
- IO Unlocked (driver circuits enabled): Contact closed between IO_LOCK+ and IO_LOCK-

Note: The IO_LOCK pins utilize an isolated RS-232 transceiver channel. IO_LOCK+ (Tx) outputs a PWM signal which must be looped-back and measured by IO_LOCK- (Rx), via ESTOP contact closure, in order for driver channels to be unlocked.

Note: Refer to **Figure 11** for recommended IO_LOCK connection to an emergency stop switch.

IO_Lock- input
(IO_LOCK- to IGND)

Input voltage range -70 V to +70 V

IO_Lock+ output
(IO_LOCK+ to IGND)

Output voltage swing +/- 5 V minimum
+/- 6 V typical

Output resistance 300Ω

Output over-voltage protection threshold -70 V to +70 V

Output short-circuit current +/- 80 mA

IO Lock

Continuous PWM output frequency	1000 Hz
Continuous PWM output duty cycle	50%
IO Locked detection time after contact open	25 ms maximum
IO Unlocked detection time after contact closed	25 ms maximum
Recommended IO Lock emergency stop switch, compatible with DCM Starter Harness	Manufacturer: ABB Jokab Safety Model: Smile 11 EA Part Number: 2TLA030051R0000

Figure 11. IO_LOCK Connection to Emergency Stop Switch (ESTOP)

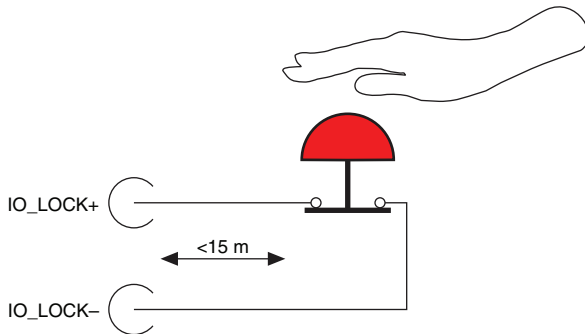

External Analog Inputs

Related Connector 1 Pins	AI1 - AI12 AGND
Configuration	<ul style="list-style-type: none"> • 12 analog input channels • Multiplexed sampling • Dedicated A/D converter • Successive Approximation Register (SAR) • No channel-to-channel isolation
Measurement range (AI to AGND)	0 V - 5 V

External Analog Inputs

Over-voltage protection (AI to AGND)	-48 V to +48 V
Measurement resolution	12-bit, 1.22 mV per count
Sample rate	1 MS/s aggregate
Hardware filter	2 nd order low-pass, $f_c = 100$ kHz
Input resistance (AI to AGND)	1 G Ω
AGND maximum continuous current	2 A

Note: AGND pin may be used as a ground reference only for external analog input pins AIx and KEY. Do not use AGND as a power ground return path for BATT or DRVP. Otherwise, the DCM may be damaged.

Internal / External System Analog Measurement

Related Connector 1 Pins	DRV_P HV_A BATT MPRD KEY
Configuration	<ul style="list-style-type: none"> • 21 internal analog channels • Multiplexed sampling • Dedicated A/D converter • Successive Approximation Register (SAR)
Measurement resolution	12-bit
Sample rate	500 kS/s aggregate
Internal System Analog Signal Sources	Range
Temp HH 1-6 [°C]	-40 °C to +125 °C
Temp HH 7-12 [°C]	-40 °C to +125 °C
Temp DI A [°C]	-40 °C to +125 °C
Temp DI Zener A [°C]	-40 °C to +125 °C
Temp DI B [°C]	-40 °C to +125 °C
Temp DI Zener B [°C]	-40 °C to +125 °C
Temp Fan Intake [°C]	-40 °C to +125 °C
Temp Primary A [°C]	-40 °C to +125 °C
Temp Secondary A [°C]	-40 °C to +125 °C
Temp Boost B [°C]	-40 °C to +125 °C
Primary A1A2 [V]	0 V - 80 V
Secondary A1A2 [V]	0 V - 240 V
Ext HV A [V]	0 V - 240 V
FET Driver [V]	0 V - 50 V
Fan [V]	0 V - 50 V

Internal / External System Analog Measurement

Battery [V]	0 V - 50 V
DRVP (Driver Power) [V]	0 V - 50 V
Key [V]	0 V - 50 V
DI Zener A [V]	0 V - 240 V
Pump Zener A [V]	0 V - 240 V
MPRD (Main Power Relay Driver) [V]	0 V - 55 V

Internal DI Scope Analog Measurement

Configuration	<ul style="list-style-type: none"> • 4 dedicated analog channels • Simultaneous sampling • 28 user-selectable signal sources for each channel • Successive Approximation Register (SAR)
Measurement resolution	15-bit
Sample rate	5 MS/s per channel
Selectable DI Scope Signal Sources	Range
I LS A1/A5 (Low-side current of DI A1 or A5)	-12 A to +50 A
I LS A2/A6 (Low-side current of DI A2 or A6)	-12 A to +50 A
I LS A8/PumpA (Low-side current of DI A8 or Pump A)	-12 A to +50 A
V PZ A1 (Piezo differential voltage of DI A1)	-250 V to +250 V
V PZ A2 (Piezo differential voltage of DI A2)	-250 V to +250 V
V S A1 (Solenoid differential voltage of DI A1)	-250 V to +250 V
V S A2 (Solenoid differential voltage of DI A2)	-250 V to +250 V
V S A5 (Solenoid differential voltage of DI A5)	-250 V to +250 V
V S A6 (Solenoid differential voltage of DI A6)	-250 V to +250 V
V S A8 (Solenoid differential voltage of DI A8)	-250 V to +250 V
V Pump A (Voltage at DI_L_AP)	-250 V to +250 V

Internal DI Scope Analog Measurement

V Secondary A1A2 (Voltage of Secondary A1A2)	0 V - 240 V
V Ext HV A (External high-voltage input to bank A secondary)	0 V - 240 V
I LS B8/PumpB (Low-side current of DI B4 or Pump B)	-12 A to +50 A
V Pump B (Voltage at DI_L_BP)	-250 V to +250 V
AI 1 (External analog input voltage at AI1)	0 V - 5 V
AI 2 (External analog input voltage at AI2)	0 V - 5 V
AI 3 (External analog input voltage at AI3)	0 V - 5 V
AI 4 (External analog input voltage at AI4)	0 V - 5 V
AI 5 (External analog input voltage at AI5)	0 V - 5 V
AI 6 (External analog input voltage at AI6)	0 V - 5 V
AI 7 (External analog input voltage at AI7)	0 V - 5 V
AI 8 (External analog input voltage at AI8)	0 V - 5 V
AI 9 (External analog input voltage at AI9)	0 V - 5 V
AI 10 (External analog input voltage at AI10)	0 V - 5 V

Internal DI Scope Analog Measurement

AI 11 (External analog input voltage at AI11)	0 V - 5 V
AI 12 (External analog input voltage at AI12)	0 V - 5 V
V DRVP (Voltage at Driver Power input pins)	0 V - 50 V

RS485 Compatible Differential Digital I/O

Related Connector 1 Pins	DIOxa DIOxb DGND (x=1-8)
Configuration	<ul style="list-style-type: none"> • 8 Differential digital IO channels • RS485-compatible transceivers • Independently configured as input or output • Can be used as differential or single-ended IO • No channel-to-channel isolation <p>Note: Refer to Figure 12 for example connections to a variety of external digital IO devices</p>
Default power-on line direction	Input
Input logic levels	
Differential (DIOxa to DIOxb)	
Input high range	200 mV to 48 V
Input low range	-200 mV to -48 V
Common mode voltage range	-15 V to +15 V
Protection ranges	15 V to 48 V, -15 V to -48 V
Single-ended (DIOxa to DGND)	
Input high range	1.8 V to 48 V

RS485 Compatible Differential Digital I/O

Input low range	0 V to 1.4 V
Input Current (e.g sensor load)	
At -7 V to +7 V	+/- 250 μ A maximum
At -15 V to +15 V	+/- 1 mA maximum
At -48 V to +48 V	+/- 6 mA maximum
Differential output voltage	
No load	5 V
100 Ω load	2.4 V minimum 3.2 V typical
54 Ω load	1.5 V minimum 2.5 V typical
Driver short-circuit current (DIOxa or DIOxb to DGND)	13 mA maximum continuous
Maximum switching frequency per channel	10 MHz (input and output)
Maximum direction change frequency	1 kHz
Input delay time	200 ns maximum
Output delay time	200 ns maximum
DGND maximum continuous current	2 A
<p>Note: DGND pin may be used as a ground reference only for digital IO signals DIOxa and DIOxb. Do not use DGND as a power ground return path for BATT or DRVP. Otherwise, the DCM may be damaged.</p>	

Figure 12. Connecting to External Digital IO Devices

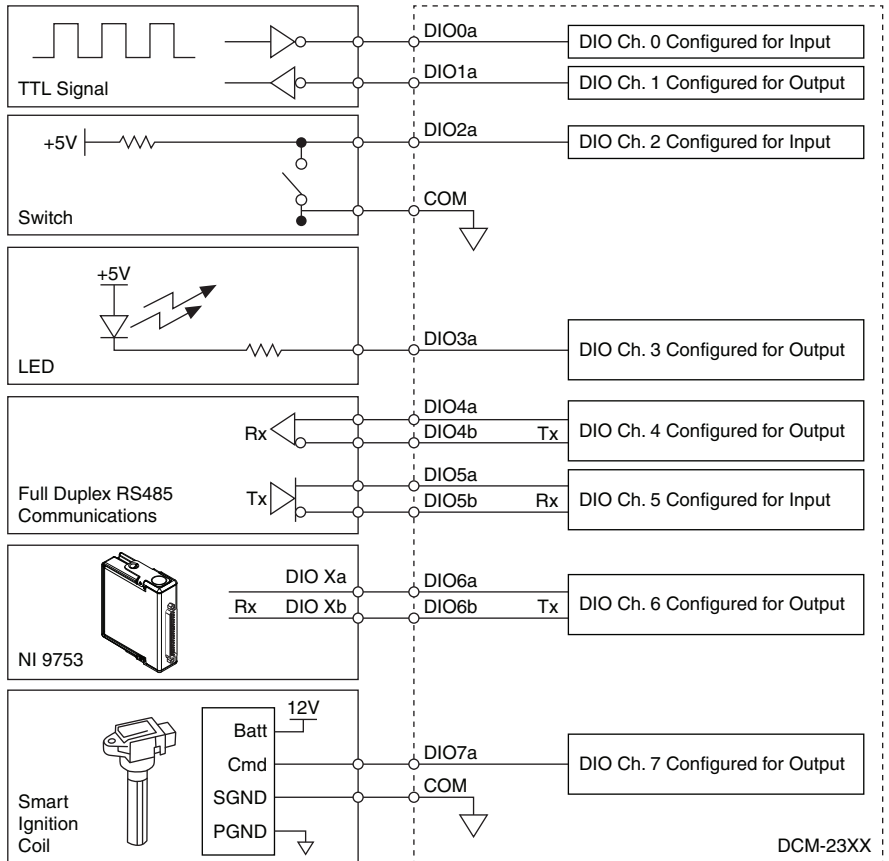

CAN

Related Connector 1 Pins	CAN_H CAN_L IGND
Configuration	<ul style="list-style-type: none">• 1 channel high-speed CAN transceiver• Fully ISO 11898-2:2003 compliant transceiver• Fault-protected• Utilizes NI Embedded CAN devices drivers• Circuitry Isolated from PGND to accommodate long distance communications with systems not tied to PGND
Baud rate	
Maximum	1 Mbps
Minimum	10 Kbps
Input voltage range (CAN_H or CAN_L to IGND)	-58 V to +58 V
Differential input voltage range (CAN_H to CAN_L)	-27 V to +27 V
Differential output voltage	
Dominant: Normal Mode	
60 Ω load	1.5 V to 3 V
2240 Ω load	1.5 V to 5 V
Recessive	
Normal mode (no load)	+/- 50 mV
Differential receiver threshold voltage (normal/silent modes)	0.5 V to 0.9 V
Receiver recessive voltage (normal/silent modes)	-3 V to +0.5 V
Receiver dominant voltage (normal/silent modes)	0.9 V to 8 V
Differential receiver hysteresis voltage (normal/silent modes)	50 mV to 200 mV

CAN

Dominant short-circuit output current	-100 mA maximum
Recessive short-circuit output current	+/- 5 mA maximum
Differential input resistance	30 kΩ
Common-mode input capacitance (CAN_H or CAN_L to IGND)	20 pF
200 mV Differential input capacitance (CAN_H to CAN_L)	10 pF
IGND isolation (IGND to all other system grounds)	250 VDC
IGND maximum continuous current	500 mA

Note: IGND is provided as a ground reference for isolated circuits CAN, RS-232 and IO_LOCK. IGND is isolated from all other DCM grounds. IGND may only be used as a reference for CAN, RS-232 and IO_LOCK pins. While IO_LOCK pins belong to the isolated circuitry, it is not necessary to utilize IGND with IO_LOCK+ and IO_LOCK- because they operate with an external passive ESTOP switch.

RS-232

DCM Connector 1 Pins	RS232_TX RS232_RX IGND
Configuration	<ul style="list-style-type: none">• 1 channel RS-232 transceiver• Fault-protected• Utilizes NI-VISA serial device drivers• Circuitry Isolated from PGND to accommodate long distance communications with systems not tied to PGND
UART/Console Out (Serial1)	
UART Specifications	
Maximum baud rate	230,400 bps
Data bits	5, 6, 7, 8

RS-232

Stop bits	1, 2
Parity	Odd, Even, Mark, Space
Flow control	None
Console Out specifications	<p>When Console Out is enabled, the Serial1 interface functions as a console for the operating system. You can use a serial-port terminal program to read the DCM IP address, read the sbRIO-9651 firmware version, and access the console. Ensure that the serial-port terminal program is configured with the following settings:</p> <ul style="list-style-type: none">• 115,200 bps• Eight data bits• No parity• One stop bit• No flow control

Note: Refer to the *Safe Mode and IP Reset (Figure 13)* section of this document for more information about how to enable Console Out.

Transceiver input (RS232_RX to IGND)

Input voltage range	-70 V to +70 V
Input threshold low	0.8 V
Input threshold high	2.4 V
Input resistance	35 k Ω to 250 k Ω

Transceiver output (RS232_TX to IGND)

Output voltage swing	+/- 5 V minimum +/- 6 V typical
Output resistance	300 Ω
Output over-voltage protection threshold	-70 V to +70 V
Output short-circuit current	+/- 80 mA

RS-232

IGND isolation (IGND to all other system grounds)	250 VDC
IGND maximum continuous current	500 mA

Note: IGND is provided as a ground reference for isolated circuits CAN, RS-232 and IO_LOCK. IGND is isolated from all other DCM grounds. IGND may only be used as a reference for CAN, RS-232 and IO_LOCK pins. While IO_LOCK pins belong to the isolated circuitry, it is not necessary to utilize IGND with IO_LOCK+ and IO_LOCK- because they operate with an external passive ESTOP switch.

Safe Mode and IP Reset

The following figure shows the reset behavior of the DCM.

Figure 13. Reset Behavior

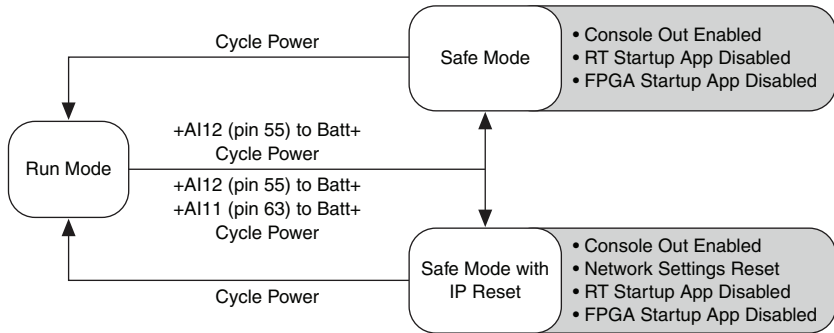

Physical Characteristics

Dimensions 19 in X 8.7 in X 4.4 in
(48.3 cm X 22.1 cm X 11.2 cm)

Weight 16.60 lbs (7.5 kg)

Note: If you need to clean the controller,
wipe with a dry towel

For indoor use only

Ventilation Clearance

Minimum vent clearance 0.75 in (19.05 mm)



Note The DCM-2301 cooling inlet air vents are located on the right side of the chassis and the outlet air vents are on the left side of the chassis. For best performance the air vents must allow easy air circulation without wiring or panels blocking the vents.

Figure 14. Airflow and Ventilation Clearance

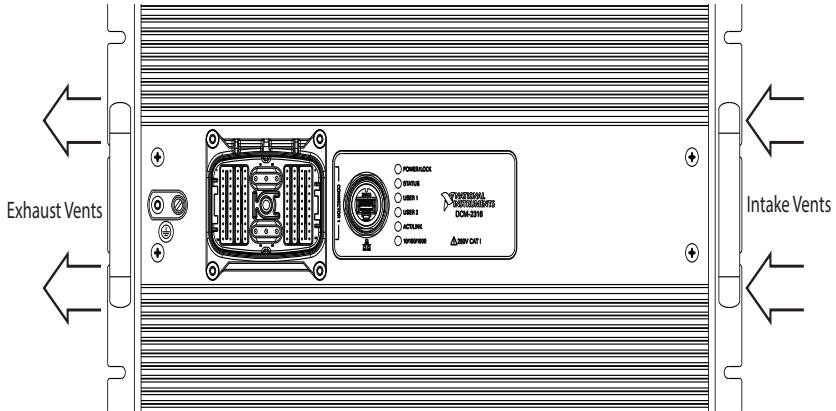

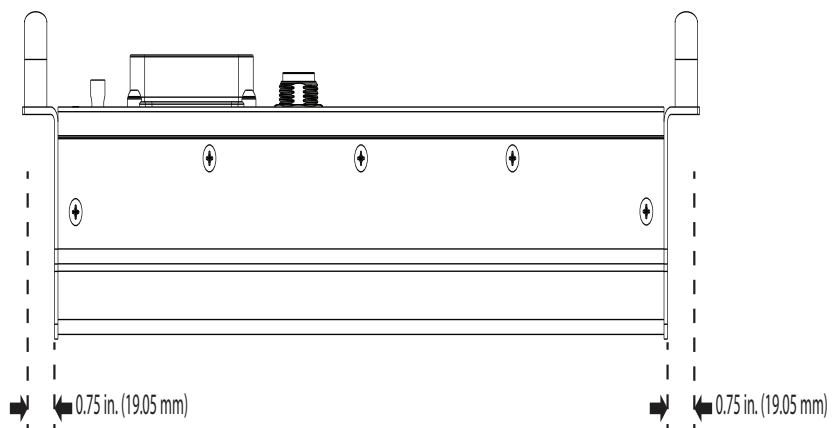
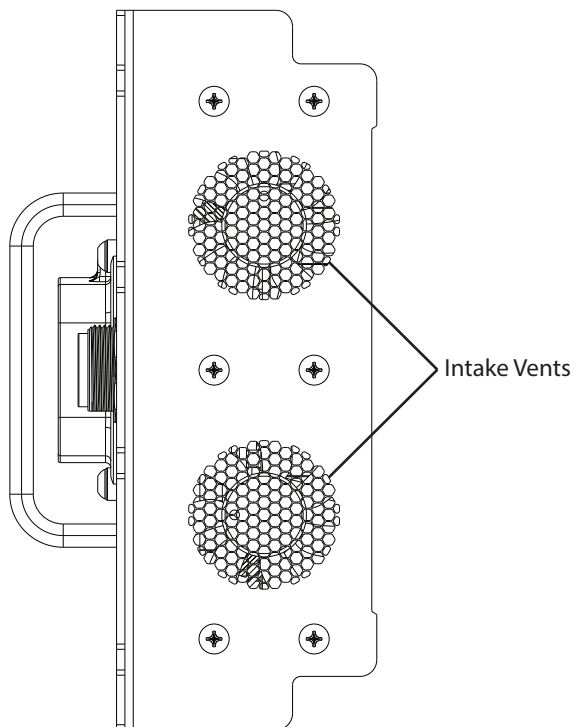

Internal Real-Time Clock Battery

Configuration	<ul style="list-style-type: none">• Internal coin cell battery maintains controller's real-time clock• Non-serviceable. Replaced by National Instruments.
---------------	--

Typical battery life with power applied to Connector 1 BATT pin	10 years
---	----------

Typical battery life in storage at 55 °C	5.7 years
--	-----------

Typical battery life in storage at 85 °C	5.3 years
--	-----------

Environmental

Temperature
(IEC 60068-2-1 / IEC 60068-2-2)

Operating	0 °C to +55 °C
-----------	----------------

Storage	-40 °C to +85 °C
---------	------------------

Ingress protection	IP 20
--------------------	-------

Operating humidity (IEC 60068-2-56)	10% RH to 90% RH, noncondensing
--	---------------------------------

Storage humidity (IEC 60068-2-56)	5% RH to 95% RH, noncondensing
--------------------------------------	--------------------------------

Pollution Degree (IEC 60664)	2
---------------------------------	---

Maximum altitude	2,000 m
------------------	---------

Shock and Vibration

Operating Shock	30 g peak, half-sine, 11 ms pulse (Tested in accordance with IEC-60068-2-27. Meets MIL-PRF-28800F Class 2 Limits)
-----------------	--

Random vibration	
------------------	--

Operating	5 to 500 Hz, 0.3 g _{rms}
Non-operating	5 to 500 Hz, 2.4 g _{rms} (Tested in accordance with IEC-60068-2-64. Non-operating test profile exceeds the requirements of MIL-PRF-28800F, Class 3.)

Safety Standards

This product is designed to meet the requirements of the following electrical equipment safety standards for measurement, control, and laboratory use:

- IEC 61010-1, EN 61010-1
- UL 61010-1, CSA 61010-1



Note For UL and other safety certifications, refer to the product label or the [Online Product Certification](#) section.

Electromagnetic Compatibility

This product meets the requirements of the following EMC standards for sensitive electrical equipment for measurement, control, and laboratory use:

- EN 61326-1 (IEC 61326): Class A emissions; Basic immunity
- EN 55011 (CISPR 11): Group 1, Class A emissions
- EN 55022 (CISPR 22): Class A emissions
- EN 55024 (CISPR 24): Immunity
- AS/NZS CISPR 11: Group 1, Class A emissions
- AS/NZS CISPR 22: Class A emissions
- FCC 47 CFR Part 15B: Class A emissions
- ICES-001: Class A emissions

These requirements and limits provide reasonable protection against harmful interference when the product is operated in the intended operational electromagnetic environment. This product is intended for use in industrial locations. However, harmful interference may occur in some installations, when the product is connected to a peripheral device or test object, or if the product is used in residential or commercial areas. To minimize interference with radio and television reception and prevent unacceptable performance degradation, install and use this product in strict accordance with the instructions in the product documentation. Furthermore, any changes or modifications to the product not expressly approved by National Instruments could void your authority to operate it under your local regulatory rules.

To ensure the specified EMC performance, you must operate this product with shielded cables and clamp-on ferrite beads as specified in Table 1 below. The clamp-on ferrite beads must be connected to the cable as close to the DCM as possible. Placing the ferrite elsewhere on the cable noticeably impairs its effectiveness.

Table 2. EMC Clamp-on Ferrite Bead and Cable Shielding

Connector 1 Pins (Names)	Cable Shielding	Clamp-on Ferrite Bead
84, 85, 86 (DRV_P)	Not Required	NI 782803-01
2, 10, (DI_S_Ax)	Not Required	NI 782803-01
3, 11, (DI_P_Ax)	Not Required	NI 782803-01
5, 13, 6, 14, 7, 15, 21, 29 (DIO1-DIO4)	Foil shield	NI 782803-01
22, 30, 23, 31, 37, 45, 38, 46 (DIO5-DIO8)	Foil shield	NI 782803-01



Note For the standards applied to assess the EMC of this product, refer to the [Online Product Certification](#) section.

CE Compliance

This product meets the essential requirements of applicable European Directives, as follows:

- 2014/35/EU: Low-Voltage Directive (safety)
- 2014/30/EU: Electromagnetic Compatibility Directive (EMC)
- 2011/65/EU: Restriction of Hazardous Substances (RoHS)

Online Product Certification

Refer to the product Declaration of Conformity (DoC) for additional regulatory compliance information. To obtain product certifications and the DoC for this product, visit ni.com/certification, search by model number or product line, and click the appropriate link in the Certification column.

Environmental Management

NI is committed to designing and manufacturing products in an environmentally responsible manner. NI recognizes that eliminating certain hazardous substances from our products is beneficial to the environment and to NI customers.

For additional environmental information, refer to the *Minimize Our Environmental Impact* web page at ni.com/environment. This page contains the environmental regulations and directives with which NI complies, as well as other environmental information not included in this document.

Waste Electrical and Electronic Equipment (WEEE)



EU Customers At the end of the product life cycle, all products *must* be sent to a WEEE recycling center. For more information about WEEE recycling centers, National Instruments WEEE initiatives, and compliance with WEEE Directive 2002/96/EC on Waste and Electronic Equipment, visit ni.com/environment/weee.

Battery Replacement and Disposal



Battery Directive This device contains a long-life coin cell battery. If you need to replace it, use the Return Material Authorization (RMA) process or contact an authorized National Instruments service representative. For more information about compliance with the EU Battery Directive 2006/66/EC about Batteries and Accumulators and Waste Batteries and Accumulators, visit ni.com/environment/batterydirective.

电子信息产品污染控制管理办法（中国 RoHS）



中国客户 National Instruments 符合中国电子信息产品中限制使用某些有害物质指令 (RoHS)。关于 National Instruments 中国 RoHS 合规性信息，请登录 ni.com/environment/rohs_china。(For information about China RoHS compliance, go to ni.com/environment/rohs_china.)

Worldwide Support and Services

The NI website is your complete resource for technical support. At ni.com/support you have access to everything from troubleshooting and application development self-help resources to email and phone assistance from NI Application Engineers.

Visit ni.com/services for NI Factory Installation Services, repairs, extended warranty, and other services.

Visit ni.com/register to register your NI product. Product registration facilitates technical support and ensures that you receive important information updates from NI.

A Declaration of Conformity (DoC) is our claim of compliance with the Council of the European Communities using the manufacturer's declaration of conformity. This system affords the user protection for electromagnetic compatibility (EMC) and product safety. You can obtain the DoC for your product by visiting ni.com/certification. If your product supports calibration, you can obtain the calibration certificate for your product at ni.com/calibration.

NI corporate headquarters is located at 11500 North Mopac Expressway, Austin, Texas, 78759-3504. NI also has offices located around the world. For telephone support in the United

States, create your service request at ni.com/support or dial 1 866 ASK MYNI (275 6964). For telephone support outside the United States, visit the Worldwide Offices section of ni.com/niglobal to access the branch office websites, which provide up-to-date contact information, support phone numbers, email addresses, and current events.

Refer to the *NI Trademarks and Logo Guidelines* at ni.com/trademarks for more information on NI trademarks. Other product and company names mentioned herein are trademarks or trade names of their respective companies. For patents covering NI products/technology, refer to the appropriate location: **Help»Patents** in your software, the `patents.txt` file on your media, or the *National Instruments Patents Notice* at ni.com/patents. You can find information about end-user license agreements (EULAs) and third-party legal notices in the readme file for your NI product. Refer to the *Export Compliance Information* at ni.com/legal/export-compliance for the NI global trade compliance policy and how to obtain relevant HTS codes, ECCNs, and other import/export data. NI MAKES NO EXPRESS OR IMPLIED WARRANTIES AS TO THE ACCURACY OF THE INFORMATION CONTAINED HEREIN AND SHALL NOT BE LIABLE FOR ANY ERRORS. U.S. Government Customers: The data contained in this manual was developed at private expense and is subject to the applicable limited rights and restricted data rights as set forth in FAR 52.227-14, DFAR 252.227-7014, and DFAR 252.227-7015.

© 2016 National Instruments. All rights reserved.
Printed in Hungary.