



O2 Sensor Module Kit User's Manual
D000025 Rev C
May 27, 2006

Introduction

The Driven cRIO O2 Sensor Module Kit provides an interface for multiple wide-band and narrow band exhaust oxygen sensors.

Features:

- 2 Ch. Bosch LSU 4.2 wide-band sensor controller
 - Fuse-protected heater control circuits (serviceable)
- 4 Ch. Narrow-band sensor input (differential)
- All channel readings updated at 1kHz
- LabVIEW FPGA and RT VIs included for quick integration with application

Pinout

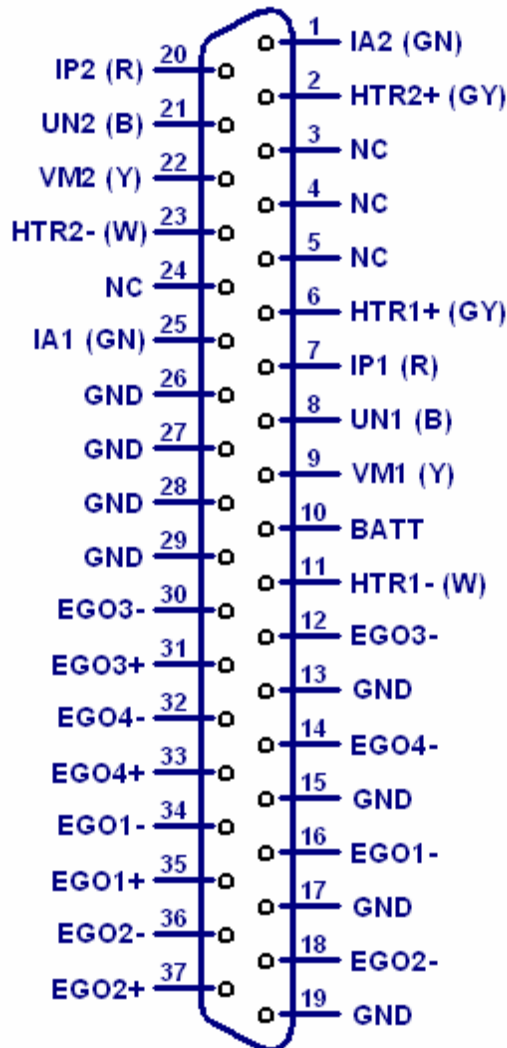

Hardware

This module provides controllers for Bosch LSU 4.2 wide-band oxygen sensors and inputs for zirconium-dioxide-element narrow-band oxygen sensors.

A properly strain relieved DB-37 connector (not included) is used to interface to the module. National Instruments provides the "cRIO-9933 37-pin Conn. Kit, screw term conn. and DSUB shell" which is compatible with this module. However, any DB-37 connector system may be used. For example, the Amp HDP-20 series connector system available from Digikey.

Powering the Module

The O2 Sensor Module requires power from two different sources.

One source is from the CompactRIO backplane male high density D-Sub 15-pin (HD15) connector which mates with the module's female HD15 connector. This power source provides a regulated 5 volts and ground to various digital logic functions within the module. The CompactRIO 5V source is active whenever the CompactRIO or R-Series Expansion Chassis is properly powered. The module should only be powered at the HD15 connector by plugging it into a CompactRIO or R-Series Expansion Chassis. The module's HD15 connector should not be connected to any other device.

Another required power connection is at the external DB-37 connector. The terminals are labeled BATT (10) and GND (29). Typical power sources will be from automotive 12V or 24V battery systems. However, the module can accept power from a range of 6V to 32V.

The external battery power ground is completely isolated, within the module, from the CompactRIO 5V supply ground. However, the external battery ground and the CompactRIO ground may be connected externally.

The module will not be recognized by software without both power supplies active.

Note: Modules of revision B and earlier have a maximum power input of 16V.

Warning: The external battery supply input pins are not reverse voltage polarity protected. Such protection would compromise certain features of the module. Connecting power to the module in reverse polarity will certainly damage the module.

Platform Compatibility

CompactRIO modules from Drivven are compatible within two different platforms from National Instruments. One platform is CompactRIO, consisting of a CompactRIO controller and CompactRIO chassis as shown in Figure 1a below.



Figure 1a. CompactRIO platform compatible with Drivven CompactRIO modules.

The other platform is National Instruments PXI which consists of any National Instruments PXI chassis along with a PXI RT controller and PXI-78xxR R-Series FPGA card. An R-Series expansion chassis must be connected to the PXI FPGA card via a SHC68-68-RDIO cable. The CompactRIO modules insert into the R-Series expansion chassis. This platform is shown in Figure 1b below.

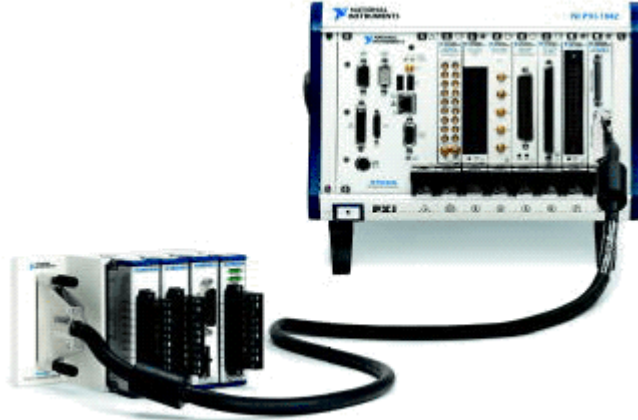

Figure 1b. PXI platform compatible with Drivven CompactRIO modules.

Drivven CompactRIO modules are not compatible with the National Instruments CompactDAQ chassis.

Drivven CompactRIO modules REQUIRE one of the hardware support systems described above in order to function. The modules may not be used by themselves and/or interfaced to third party devices at the backplane HD15 connector. These efforts will not be supported by Drivven or National Instruments.

Bosch LSU 4.2 Wide-Band Oxygen Sensor Controllers

The O2 Sensor Module Kit provides two identical Bosch LSU 4.2 sensor controllers. They are called controllers because there is much more involved than just sensing a voltage signal from the sensor. In general, the module controls the current (pump current, I_p) to the sensor element so as to maintain a fixed voltage reference across the element. The exhaust oxygen content, and therefore the air-fuel mass ratio, is proportional to I_p . The temperature of the sensor element is also critical in order to obtain a good exhaust oxygen measurement. The module controls the sensor element temperature to 750 degrees Celsius.

The detailed description and internal operation of a wide-band oxygen sensor and its control is beyond the scope of this document. The purpose of this document is to instruct the user on how to properly connect the module to the Bosch LSU 4.2 sensor and operate the provided VIs to interface with the module.

The Drivven O2 Sensor Module Kit wide-band sensor controllers are only intended to be used with the widely available production Bosch LSU 4.2 sensors. Another common wide-band sensor is also available from NTK, but is not compatible with this module kit.

Sources for Bosch LSU 4.2 Sensors, Connectors, Cables, etc.

Bosch LSU 4.2 wide-band oxygen sensor part number:

0 258 007 057 (2X3 pin connector system)

0 258 006 066 (1X6 pin connector system)

Both of the above Bosch part numbers are identical in function and compatibility with the Drivven O2 Sensor Module Kit. However, this document will discuss the 7057 model in detail.

NOTE: The 7057 and 6066 sensor models have different pin numberings, but identical wire coloring. This document discusses the more available 7057 model and provides a connection diagram. If the 6066 model is used, do not follow the 7057 pin numbering in this document. Instead follow the wire coloring.

Volkswagen OEM part number for Bosch LSU 4.2 7057 model

021-906-262-B

Available from www.1stvwparts.com

Volkswagen OEM part number for 6-pin 2X3 mating connector housing:

1J0973733

Available from www.1stvwparts.com

Volkswagen OEM part number for wire leads with pin sockets on each end (3 required):

000979133A

Available from www.1stvwparts.com

Volkswagen OEM part number for wire grommets (6 optional):

357972741A

Available from www.1stvwparts.com

For cabling, Drivven recommends using a 6-conductor (22 AWG), non-plenum, unshielded cable having stranded, tinned copper wires. Drivven suggests the following part number from Digikey: W124-X-ND

The above suggested cable has wire color coding according to:

- No. 1 – Black
- No. 2 – White
- No. 3 – Red
- No. 4 – Green
- No. 5 – Brown
- No. 6 – Blue

This color coding will be assumed for the wiring description below.

For oxygen sensor port bungs, Drivven suggests searching the Summit Racing website with the following phrase:

weld in oxygen sensor bungs

Several options for oxygen sensor bungs will be presented. However, they will all have the same standard threads.

Drivven makes available a Bosch LSU 4.2 7057 sensor package which includes the following:

Bosch LSU 4.2 7057 Sensor

10 foot cable with mating Bosch LSU 4.2 2X3 connector (loose wires on opposite end)

Sensor bung

Drivven's Bosch LSU 4.2 7057 sensor package is listed on the www.drivven.com website under part number D000027, along with the O2 Sensor Module Kit.

Adding the Sensor Cable to the Module Connector

The color coding of the Bosch LSU 4.2 wide-band sensor wires differ from the available color coding in a 6-conductor cable. The following table and figure shows the proper connection from the LSU 4.2 7057 sensor connector, to the intermediate cable, to the Drivven module. The Drivven module label provides wire color information next to its DB-37 pin names according to the standard Bosch LSU 4.2 sensor wire coloring, not according to any intermediate wiring. Note that the 7057 model pin 2 does not actually have a green wire from the sensor to the connector.

There is a calibration resistor feeding this connector pin. The color code of green has been the standard color for the calibration sensor location.

Table 1. Bosch LSU 4.2 7057 Sensor Connection

Module Pin Label	Intermediate Cable Wire Color	LSU 4.2 Wire Color	LSU 4.2 7057 Pin Number
UN (B)	Black	Black	1
IA (GN)	Green	N/A	2
HTR+ (GY)	Brown	Grey	3
HTR- (W)	White	White	4
VM (Y)	Blue	Yellow	5
IP (R)	Red	Red	6

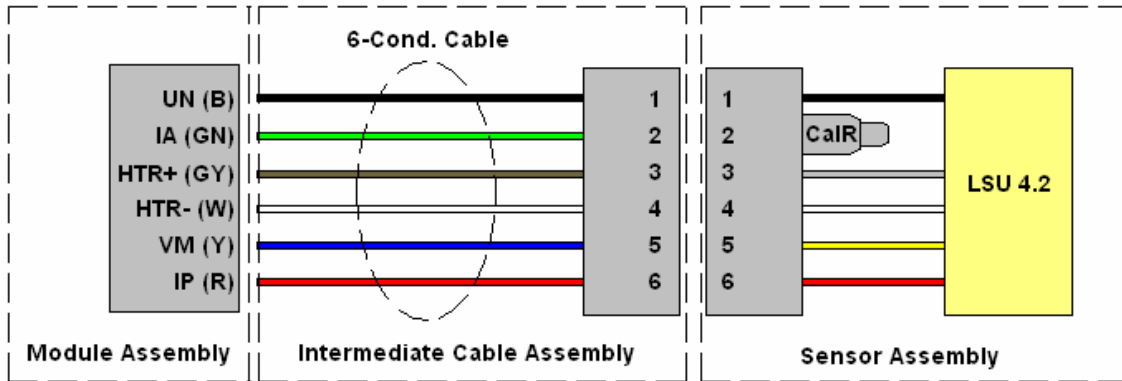

Figure 2. Bosch LSU 4.2 7057 Sensor Wiring

If you choose to use a Bosch LSU 4.2 sensor that has a connector other than the 2X3 D-shape connector (such as the 6066 model), then you must follow the standard LSU 4.2 wire color code and not the LSU 4.2 7057 pin number association from Table 1.

A single fuse is located in the module circuit which feeds battery voltage to both sensor heaters. The status of the fuse is provided in software by the UEGOFuseStatus enumerated integer within the UEGO Diagnostics cluster of the RT VI.

Digikey part number for Littelfuse R451 Series Nano SMF 5.0 amp fast acting replacement fuse: F1149CT-ND

Narrow-Band Oxygen Sensor Inputs

The O2 Sensor Module Kit provides four identical zirconium-dioxide-element, narrow-band (switching), oxygen sensor inputs.

The detailed description and internal operation of a narrow-band oxygen sensor is beyond the scope of this document. The purpose of this document is to instruct the user on how to properly connect the module to a variety of zirconium-dioxide-element oxygen sensors and operate the provided VIs to interface with the module.

There are a number of different types of standard zirconium-oxide-element oxygen sensors which the Drivven O2 Sensor Module Kit supports. From here we will refer to these sensors as Exhaust Gas Oxygen (EGO) sensors. These sensors may also be referred to in other literature as lambda sensors. This document will discuss EGO sensor wires in terms of “universal” EGO sensors which have a standardized wire color code. OEM-specific EGO sensors may have a different wire color code and should be further researched to determine what function is associated with each wire. Four different EGO sensors are discussed below, however, Drivven recommends the use of the 4-wire, heated, universal EGO sensor.

1-Wire Universal EGO Sensors

1-Wire EGO sensors have a single black wire which provides the lambda signal and is referenced to the sensor body or engine/exhaust system ground. The black wire must be connected to the EGO+ pin of the module DB-37 connector. Also, a wire jumper must be connected from one of the module EGO- pins for the associated EGO channel to one of the module GND pins.

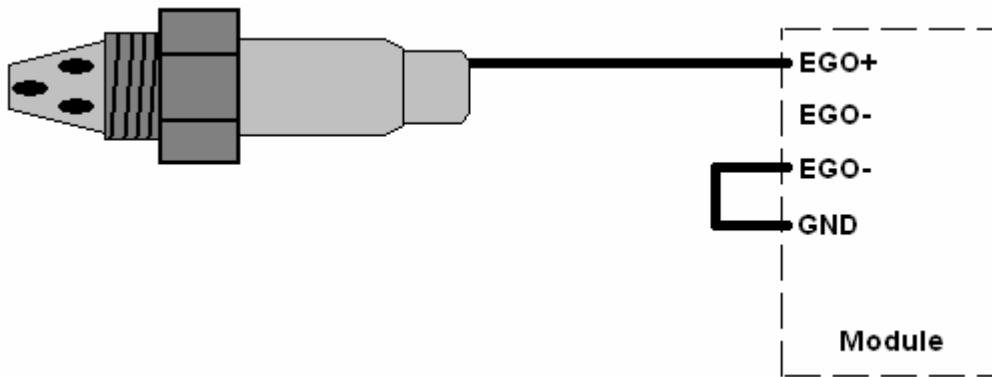

Figure 3. 1-Wire EGO Sensor Connection

2-Wire Universal EGO Sensors

2-Wire EGO sensors have black and gray wires which provide a differential lambda signal. The black wire must be connected to the EGO+ pin of the module DB-37 connector. The gray wire must be connected to one of the EGO- pins for the associated channel of the module DB-37 connector. Also, a wire jumper must be connected from the other EGO- pin for the associated EGO channel to one of the module GND pins.

If using a non-universal EGO sensor with different wire colorings, then it may require a trial and error process to get the wiring polarity correct. The sensor will not be damaged if the wire polarity is reversed, however, the sensor will not provide a correct reading and will likely show up as a cold sensor in the software.

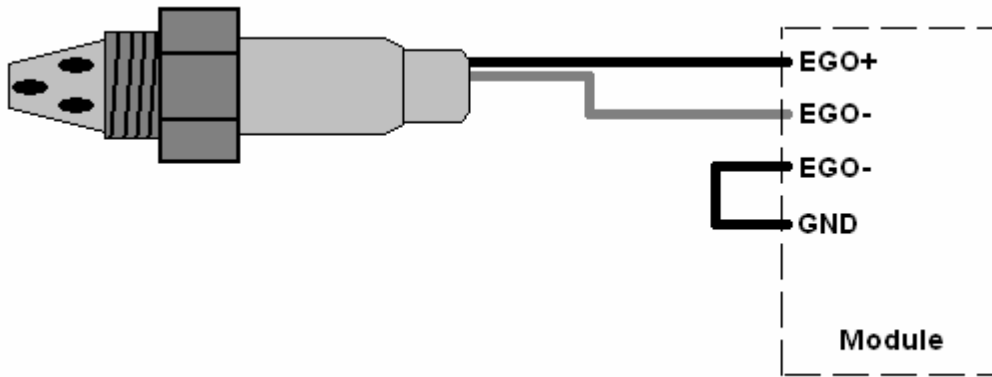

Figure 4. 2-Wire EGO Sensor Connection

3-Wire Universal Heated EGO Sensors

3-Wire EGO sensors have a black wire and two white wires. The black wire provides the lambda signal and is referenced to the sensor body or engine/exhaust system ground. The black wire must be connected to the EGO+ pin of the module DB-37 connector. Also, a wire jumper must be connected from one of the module EGO- pins for the associated EGO channel to one of the module GND pins. The two white wires connect to a resistive heater element inside the EGO sensor. These wires should be connected to 12 volts and ground. The O2 sensor module does not provide connections for these wires. They must be connected to a power source externally. The user may wish to power them via a relay which is energized with the main ignition switch and optionally insert a 3 amp fuse per sensor. If using a non-universal EGO sensor with different wire colorings, then you must first identify the two wires which are connected to the heater element. This can be determined by testing for approximately 5 ohms across two of the wires. The remaining wire is the lambda signal wire.

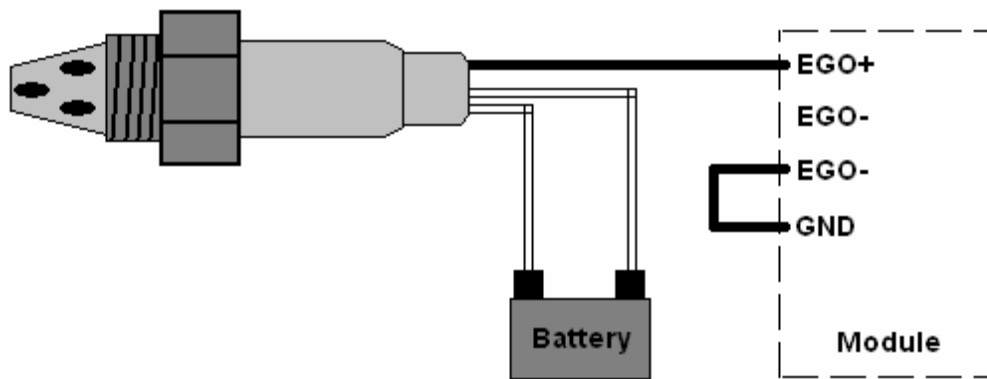

Figure 5. 3-Wire EGO Sensor Connection

4-Wire Universal EGO Sensors

4-Wire EGO sensors have a black and gray wire and two white wires. The black and gray wires provide a differential lambda signal. The black wire must be connected to the EGO+ pin of the module DB-37 connector. The gray wire must be connected to one of the EGO- pins for the associated channel of the module DB-37 connector. Also, a wire jumper must be connected from the other EGO- pin for the associated EGO channel to one of the module GND pins. The two white wires connect to a resistive heater element inside the EGO sensor. These wires should be connected to 12 volts and ground. The O2 sensor module does not provide connections for these wires. They must be connected to a power source externally. The user may wish to power them via a relay which is energized with the main ignition switch and optionally insert a 3 amp fuse per sensor. If using a non-universal EGO sensor with different wire colorings, then you must first identify the two wires which are connected to the heater element. This can be determined by testing for approximately 5 ohms across two of the wires. The remaining two wires are the differential lambda signal wires. It may require a trial and error process to get the lambda signal wiring polarity correct. The sensor will not be damaged if the wire polarity is reversed, however, the sensor will not provide a correct reading and will likely show up as a cold sensor in the software.

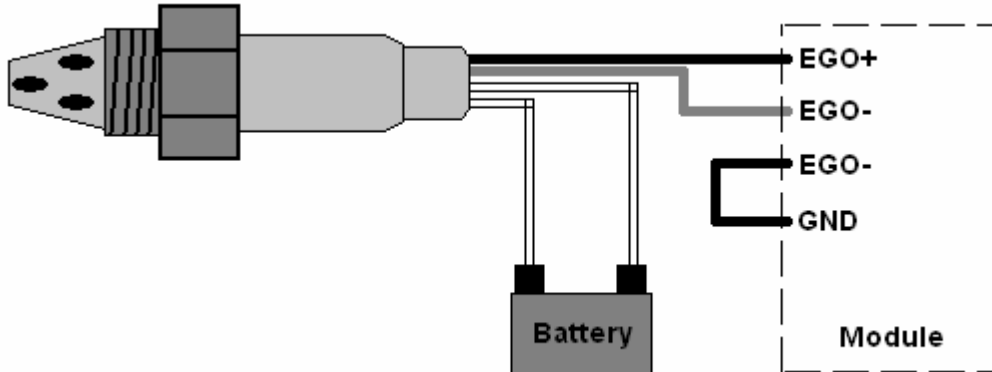

Figure 6. 4-Wire EGO Sensor Connection

Sources for EGO Sensors and Connectors

There are many compatible EGO sensors available, but Drivven will recommend one 4-wire sensor and connector system.

Bosch part number for 4-wire premium oxygen sensor:
15717

An internet search on this part number will show several listings of this sensor for sale for approximately \$45-\$55. The sensor is commonly found on Ford vehicles and will have a round 4-pin connector attached as shown in the figure below.

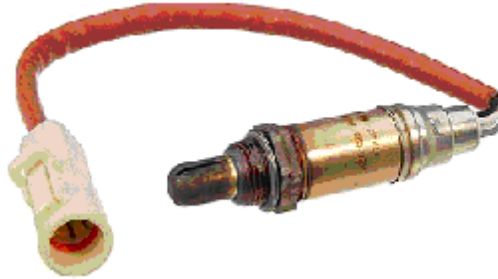

Figure 7. Bosch 15717 sensor

A mating connector is available from www.rockauto.com under part number:
S631

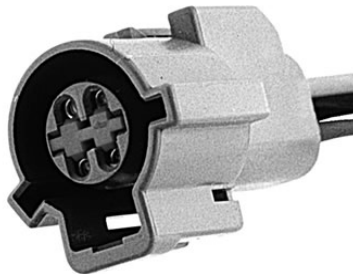

Figure 8. Mating connector (S631) for Bosch 15717 sensor

Drivven makes available a Bosch 15717 4-wire sensor package which includes the following:
Bosch 15717 4-Wire Sensor
10 foot cable with mating Bosch 15717 4-wire sensor connector (loose wires on opposite end)
Sensor bung

Drivven's Bosch 15717 4-wire sensor package is listed on the www.drivven.com website under part number D000028, along with the O2 Sensor Module Kit.

Module Connector Parts and Tools

Drivven recommends the following part numbers available from Digikey:

Digikey part number for Amp female DB-37 HDP-20 zinc plated shell:
A1007-ND

Digikey part number for Amp HDP-20 crimp type sockets (22-18 AWG)
A5804CT-ND

Digikey part number for Amp DB-37 hood
A2058-ND

Digikey part number for Amp Pro Crimper II with DB die set
A9990-ND

Drivven does not offer the Amp connector parts or tools from its website.

Software

The O2 Sensor Module Kit is provided with both a LabVIEW FPGA VI for interfacing directly to the module and a LabVIEW RT VI for interfacing with the FPGA VI and managing and reporting sensor results.

Figure 9 shows the icon which represents FPGA uego_rev.vi.

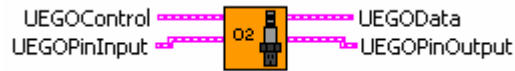

Figure 9. FPGA VI icon with leads.

Figure 10 shows the icon which represents uego_rt_rev.vi.

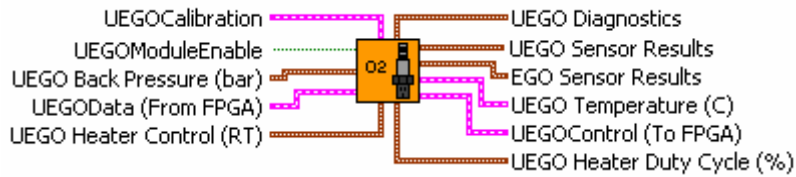

Figure 10. RT VI icon with leads.

VERY IMPORTANT NOTES:

The FPGA VI requires:

- LabVIEW 8.0 or later
- LabVIEW RT Module 8.0. or later
- LabVIEW FPGA Module 8.0 or later
- NI-RIO 2.0 or later

The FPGA VI must be placed within a Single Cycle Loop (SCL) of a LabVIEW FPGA block diagram. The SCL must execute at the default clock rate of 40 MHz.

The FPGA VI requires a pre-synthesized netlist file having a matching name and an extension of .ngc. The netlist file must be located in the same directory as the matching VI.

The FPGA VI requires the installation of a special CompactRIO module support package called cRIO-generic. Please follow the steps below to install the cRIO-generic package:

1. Confirm that LabVIEW is closed.
2. Add the line `cRIO_FavoriteBrand=generic` to the LabVIEW INI file. The LabVIEW INI file is typically found at C:\Program Files\National Instruments\LabVIEW 8.0\LabVIEW.ini.
3. Upon restarting LabVIEW, the cRIO-generic module will appear in the list of available modules within the LabVIEW FPGA “New C Series Module” configuration dialog. All Drivven CompactRIO modules require adding an associated cRIO-generic module to your LabVIEW Project. Within the Project Explorer, A cRIO-generic module can be added to a PXI FPGA expansion chassis or a CompactRIO chassis. This is best understood by observing an example project provided with your module kit.

WARNING!

When writing values to an FPGA cluster from the RT level, every parameter within the cluster must be explicitly written. If any parameter is not explicitly written, then the default value for that particular data type will be used. This could cause unexpected behavior.

FPGA VI Implementation

The FPGA VI must be contained within a single cycle loop and clocked at 40 MHz. The PinInput and PinOutput clusters are wired to LabVIEW FPGA I/O pins which are configured for a cRIO controller chassis or a cRIO R-Series expansion chassis. Refer to the LabVIEW FPGA documentation for details about configuring cRIO I/O pins.

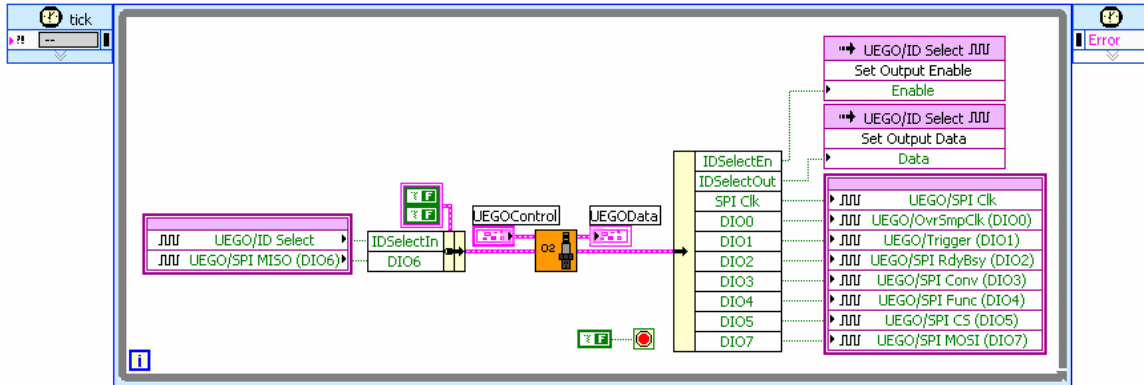

Figure 11. Example FPGA block diagram implementation of uego_revx.vi.

UEGOPinInput (Cluster)

The UEGOPinInput cluster contains two boolean controls which must be connected to their corresponding cRIO I/O pin using a Digital Input function.

UEGOPinOutput (Cluster)

The UEGOPinOutput cluster contains ten boolean indicators which must be connected to their corresponding cRIO I/O pins. The boolean indicator named IDSelectEn must be connected using a Digital Enable function. The boolean indicator named IDSelectOut must be connected using a Digital Data function. The remaining boolean indicators must be connected using a Digital Output function.

WARNING!

Great care must be taken to ensure that FPGA output pins are only driven by a single logic source. There is no circumstance in which FPGA pins should be driven by multiple sources when interfacing to cRIO modules. If FPGA output pins are driven by multiple sources, very strange behavior and even module damage could result. This is especially true when the module being controlled is an actuator driver. For example, if an output to an AD Combo module was also accidentally driving an output to a Spark Driver module, then the Spark Driver module could behave incorrectly, or even continually turn on one of the spark driver outputs such that the ignition coil or driver circuit would be damaged.

One way this situation can be prevented is by making sure that all FPGA outputs are configured to “Arbitrate if Multiple Accessors Only.” When outputs are configured this way and they are used within a Single Cycle Loop (as is required by Drivven cRIO module kits), then a compile error will be generated if multiple sources are driving FPGA outputs. Then appropriate corrective action can be taken. FPGA outputs can be configured via the FPGA I/O properties dialog. FPGA output properties should be set according to the following dialog screen shot.

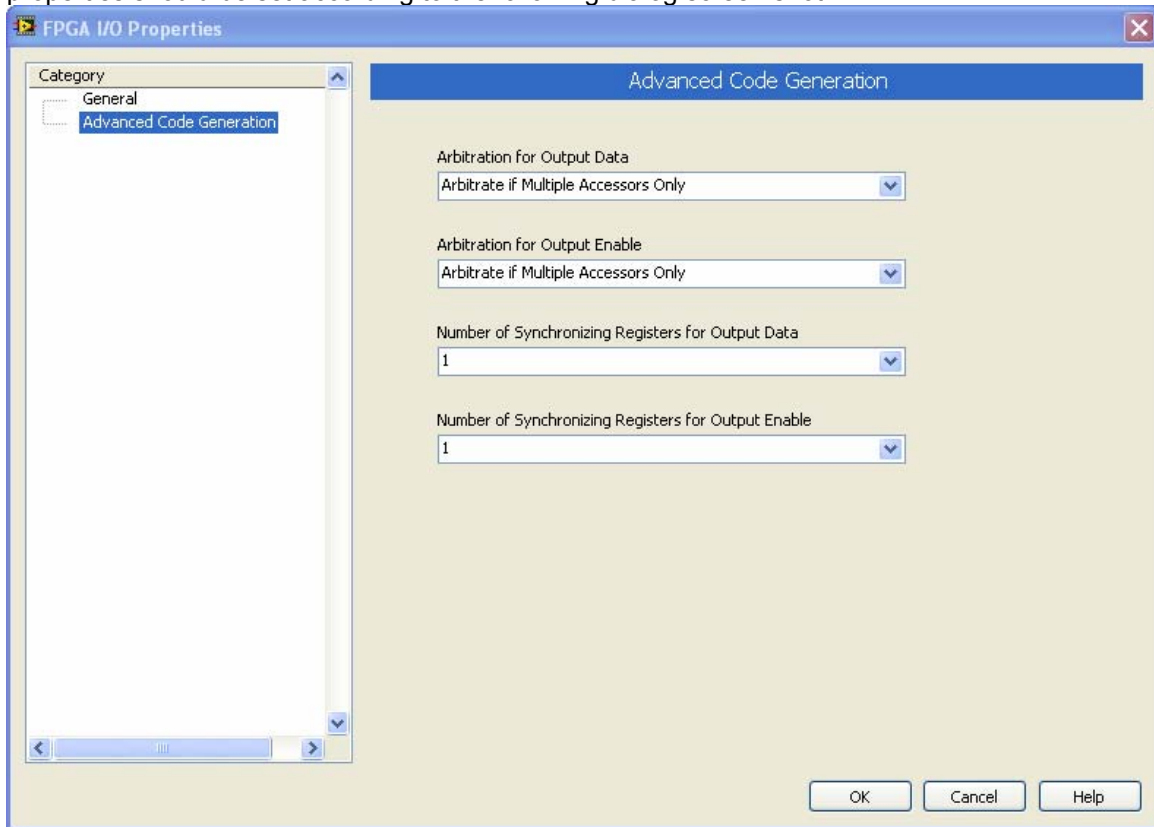

Figure 12. FPGA I/O Properties dialog configuration for cRIO modules.

UEGOControl (Cluster)

The UEGOControl Cluster should be terminated with a control cluster and made available as a complete cluster for interfacing to the RT VI. No FPGA code interface is required with any of the members of this cluster.

UEGOData (Cluster)

The UEGOData Cluster should be terminated with an indicator cluster and made available as a complete cluster for interfacing to the RT VI. No FPGA code interface is required with any of the members of this cluster.

RT VI Implementation

The `uego_rt_revx.vi` (RT VI) must be placed within a while loop or timed loop and executed at a minimum rate of 10 Hz. This is the minimum rate to maintain the watchdog within the module. A reference must be opened to a LabVIEW FPGA application which implements the `uego_revx.vi`. Also, FPGA read/write register functions must be placed within the RT loop to gain access to the UEGOControl and UEGOData clusters of the FPGA `uego_revx.vi`. This is shown in Figure 13.

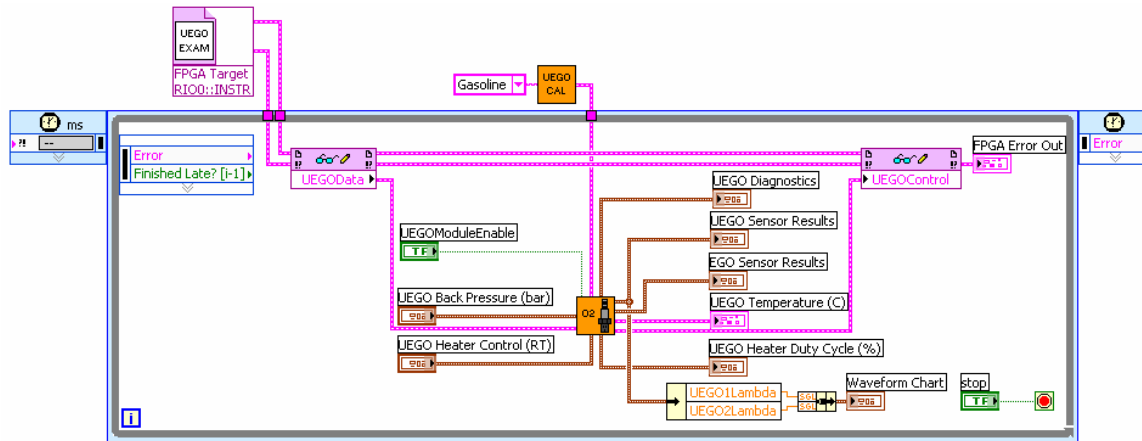

Figure 13. Example RT implementation of `uego_rt_revx.vi`.

UEGOModuleEnable (boolean)



UEGOModuleEnable (boolean): If the RT VI detects a powered O2 sensor module in the correct slot and UEGOModuleEnable is TRUE, then the RT VI begins initializing the wide-band sensors, bringing them up to temperature, and updating sensor results in the UEGO Sensor Results cluster. If the module is present but no sensors are connected, then the RT VI will time out (30 seconds) with its attempt to bring the sensors up to temperature and discontinue heater control. UEGOModuleEnable must be set to FALSE and back to TRUE in order to make another attempt at sensor control. It is important that disconnected wide-band sensors are NOT connected while UEGOModuleEnable is TRUE. It is possible to damage the sensor element of a cold sensor if the sensor connection is made while the UEGOModuleEnable is TRUE and the heater duty cycle is approaching 100%. Sensors should already be connected when UEGOModuleEnable is set to TRUE so that the temperature is brought up according to a profile specified by Bosch.

UEGO Sensor Results (Cluster)

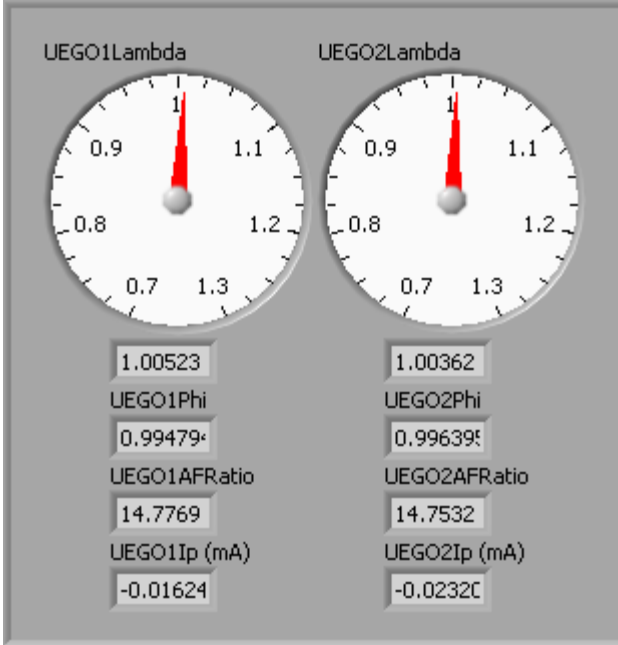

UEGOXLambda (single): Also represented by the Greek character λ , the actual air-fuel mass ratio divided by the stoichiometric air-fuel mass ratio. Lambda is equivalent to $1/\Phi$.

UEGOXPhi (single): Also represented by the Greek character Φ , the actual fuel-air mass ratio divided by the stoichiometric fuel-air mass ratio. Phi is equivalent to $1/\text{Lambda}$.

UEGOXAFRatio (single): The actual air-fuel mass ratio.

UEGOXIp (single): The pump current required for maintaining a reference voltage of 450 millivolts across the wide-band sensor element. This is also the current required for maintaining a stoichiometric gas mixture within the sensor element.

UEGO Diagnostics (Cluster)

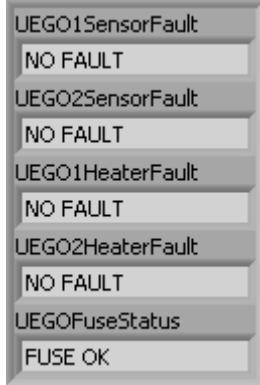

UEGOXSensorFault (enumerated uint8):

NO FAULT – No faults exist with the sensor signal wires.
 SHORT TO GND OR BATT – A short to ground or battery is present on one of the sensor signal wires.

UEGOXHeaterFault (enumerated uint8):

NO FAULT – No faults exist with the sensor heater wires.
 SHORT TO GROUND – A short to ground is present on one of the sensor heater wires.
 OPEN CIRCUIT – An open circuit is present on one of the sensor heater wires.
 SHORT TO BATTERY – A short to battery is present on one of the sensor heater wires.

UEGOFuseStatus (enumerated uint8):

A single fuse is located in the module circuit which feeds battery voltage to both sensor heaters.
 FUSE OK – The heater circuit fuse is OK.
 FUSE BLOWN – The heater circuit fuse is blown.

Digikey part number for Littelfuse R451 Series Nano SMF 5.0 amp fast acting replacement fuse: F1149CT-ND

UEGO Back Pressure (bar) (Cluster)

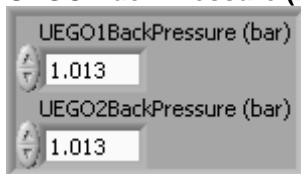

UEGOXBackPressure (bar) (single): The air-fuel mass ratio results are dependent on exhaust system pressure. Many engine systems will have exhaust systems which are very near atmospheric pressure. In this case, this control may be set to a constant value of 1.013 bar. However, if exhaust system pressure is expected to depart from atmospheric pressure, then the pressure should be wired to this control.

UEGO Heater Control (RT) (Cluster)

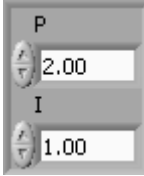

P (single): The proportional gain constant for the heater temperature PI control algorithm. In most cases, this control may be left at the default value of 2.00.

I (single): The integral gain constant for the heater temperature PI control algorithm. In most cases, this control may be left at the default value of 1.00.

UEGO Temperature (C) (Cluster)



UEGOXTemp (C) (single): The controlled temperature, in degrees Celsius, of the wide-band sensor element.

UEGOXHot (boolean): When TRUE, the wide-band sensor element temperature is above 720 degrees Celsius and the air-fuel mass ratio and related values may be used. When FALSE, the air-fuel mass ratio and related values should not be used. UEGOXHot will transition from TRUE to FALSE at 700 degrees Celsius.

UEGO Heater Duty Cycle (%) (Cluster)

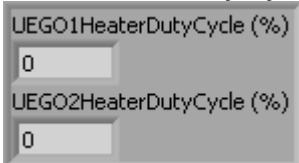

UEGOXHeaterDutyCycle (%) (single): The heater duty cycle values are brought out for debug purposes only.

EGO Sensor Results (Cluster)

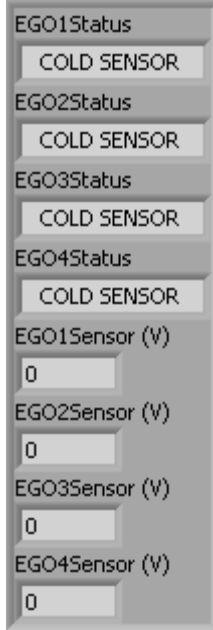

EGOXStatus (enumerated uint8):

COLD SENSOR – When a narrow-band sensor is cold, the sensor input circuit will report a voltage of approximately 450 millivolts and will not fluctuate with rich and lean exhaust mixtures. This enumeration is reported when the sensor value remains in the range of 400 to 500 millivolts for a period of 1 second.

FOULED SENSOR – When a narrow-band sensor is fouled or aged, the sensor value will transition from rich to lean and from lean to rich much slower than that of a normally operating sensor. This enumeration is reported when the sensor value takes longer than 1 second to transition from below 300 millivolts to above 600 millivolts or vice versa.

RICH: - The sensor is sourcing a voltage of greater than 600 millivolts

LEAN: - The sensor is sourcing a voltage of less than 300 millivolts

EGOXSensor (V) (single): The voltage being sourced by the EGO sensor.

Wide-Band Sensor Calibration

Included within the O2 Sensor Module Kit software bundle is a VI named `uego_calibration.vi`. The cluster indicator output of this VI, named `UEGOCalibration` must be connected to the `UEGOCalibration` cluster control input of the `uego_rt_revx.vi`. The `uego_calibration.vi` contains a simple case structure which selects the constant calibration arrays for I_p versus Lambda. By default, there are two cases established for Fuel Selection of Gasoline and Diesel. These calibrations are identical and are derived from the datasheet for the Bosch LSU 4.2 sensor. The user has the ability to create additional calibration cases for any other fuel type and also check and/or tweak the existing gasoline and diesel calibrations against a more precisely calibrated emissions bench. The calibration procedure is simple. First, adjust the exhaust gas mixture to achieve a pre-determined I_p reading from the UEGO Sensor Results cluster. This I_p value calibration point would be entered into the constant I_p array. Then take a lambda reading from the secondary calibrated equipment and enter this lambda value in the constant lambda array for the corresponding I_p array entry. I_p values in the constant I_p array must be increasing. The `uego_rt_revx.vi` uses these two constant arrays within an interpolation lookup table algorithm to calculate the lambda value based on the sensed I_p value. Phi and AFRatio are then derived from lambda.

Examples

The following screen captures show the implementation of the `uego_revx.vi` and the `uego_rt_revx.vi` within the LabVIEW FPGA and LabVIEW RT environments, respectively. Both implementations are required for using the O2 Sensor Module Kit. You will find these implementations within the software bundle for the kit. The FPGA project file is named `UEGO_Example.lep` and the top level FPGA VI is named `UEGO_Example.vi`. `UEGO_Example.vi` implements `uego_revx.vi`. You will also find an RT VI named `UEGO_RT_Example.vi` which implements `uego_rt_revx.vi`. The RT example VI shows how the interface takes place with the FPGA application. Most likely your application will require additional features and Driven module implementations. At the FPGA level, you can include other module interface VIs within the same single cycle loop. Likewise, at the RT level you can include FPGA interface code for the additional modules within the same timed loop.

The FPGA application is entirely contained within a single cycle loop, clocked at the required 40 MHz. The PinInput and PinOutput clusters are wired to LabVIEW FPGA I/O pins which are configured for a cRIO controller chassis or a cRIO R-Series expansion chassis. Refer to the LabVIEW FPGA documentation for details about configuring cRIO I/O pins.

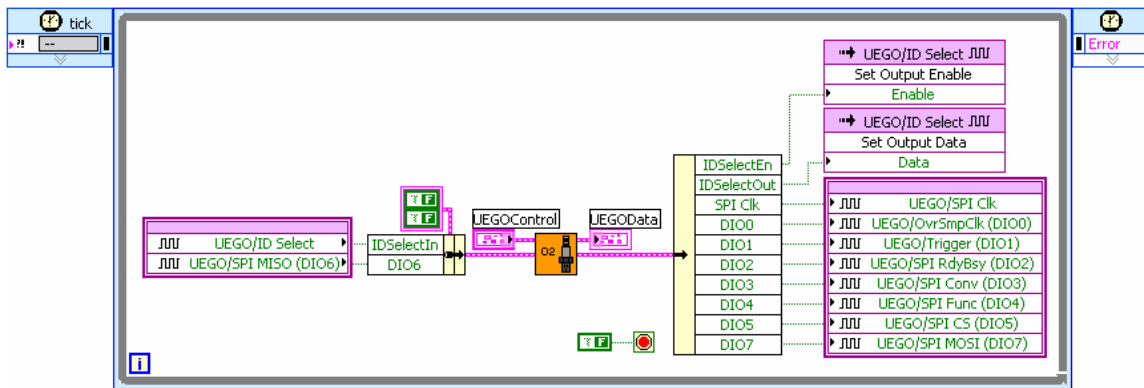

Figure 14. LabVIEW FPGA Block diagram example of `uego_revx.vi`

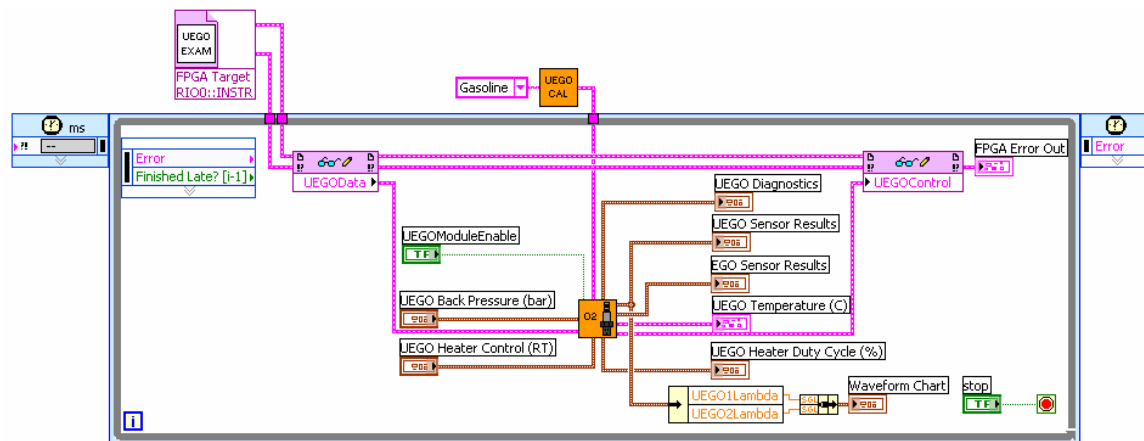

Figure 15. LabVIEW RT Block diagram example of `uego_rt_revx.vi`